

# Development of Prompt Inferno Reporting System for Curbing the Losses of Fire Outbreak

Olumuyiwa P. Aiyelabowo<sup>1</sup>, Babajide A. Ojo<sup>2</sup>, Suraj A. Fadare<sup>3</sup>, and Oluwafemi T. Mathew<sup>4</sup>  
<sup>1,2,3,4</sup>Department of Electrical/Electronic Engineering, the Federal Polytechnic, Ilaro, Ogun State, Nigeria

## Abstract

Fire is useful for several human activities and is a very important article for human survival. As good and required as fire is, it can cause disaster to man. Report has shown that fire has caused so many losses in assets, lives and property. Often times, this inferno occurs in the night when no one is available to put a call to the firefighting centre, thus there is often no response to the inferno. A system that reports an inferno remotely is designed and developed in the system. It consists of a sensing unit that senses smoke, carbon monoxide, flame and increase in temperature in the secured environment. Through a microcontroller and a communication module, information regarding the inferno is routed to the fire-fighting centre. This information equips the centre to combat the inferno promptly.

**Keywords** - smoke, carbon-monoxide, MQ-2, MQ-7, ATmega138 and inferno.

## I. INTRODUCTION

Fire is a required commodity in some instances can be a worst enemy when consuming an edifice uncontrollably. It can be destructive and smoke a component fire, toxic[1]. For the vastness and entirely destructive nature of fire, it constitute a gruesome treat to life and property and its effect in inferno is the most dangerous event to mankind. Structures that are environmentally damaged or vandalized can be repaired, but structures in inferno are lost completely. Detecting inferno and responding to it promptly can save several thousands of lives, injuries and millions of property loss each year[1], [2].

A prominent activity in fire protection is the prompt identification of fire emergence and prompt reporting of the inferno to the rescuing organizations. There have been different methods of attending to inferno reports, some are archaic while others are modern, using fire detection alarm systems. Most times, inferno is communicated to the firefighting services through phone calls that is people in the neighbourhood puts a call to the firefightingcentre. This call most times does not contain the vital information required by the agency to combat the inferno. The reception of the inferno alert is also delayed, thus making the agency to arrive late or unequipped to the inferno scene.

In this paper, a system that reports an inferno promptly is developed. The system reports information regarding the time of occurrence of the inferno, the address of the scene, proffers all the routes distances from the scene of the inferno to the fire-fighting centre. To ensure adequate dissemination of the inferno occurrence, it communicates the occurrence to the occupants of the house and honks an alarm at the scene of the inferno and at the firefightingcentre.

## II. RELATED WORKS

For a long time, research in fire surveillance has been expounded and gaining advancement over the years. Various networking techniques has been developed to widen the research scope to cover large-scale remote monitoring. Various fire alarm system have been invented or designed. Broadly speaking, two generic types, wired networks and wireless sensor networks (WSN). The latter is expensive and may not be adaptable to some environment, while the former requires regular maintenanceof the wireless sensor to achieve efficient performance. In [3], wireless communication was considered for fire detection systems, its reliability was investigated and the parameters that influences the propagation of the radio wave within the building was analysed. The Authors in [4] proposed wireless sensor networks for fire detection and rescue support framework. In South Korean mountains, forest fire surveillance system was developed in [5].

The deployment in this work is a hybrid of wired and wireless, the sensors were connected strategically within the building. Its output connects via wire to the control system and the control system at the sensing end communicates with the firefightingcentre via wireless. The hardware and software were developed in this paper.

## III. METHODOLOGY

The activities carried out in the method of the developing the system includes the following;

- Area Survey
- System design

Figure 1 shows the methodology scenario deployed

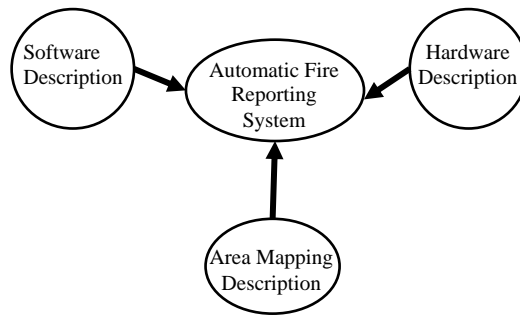

Figure 1: Methodology scenario

**A. Area Mapping**

The case study for the development of the fire reporting system is the Campus of the Federal Polytechnic, Ilaro, Ogun State Nigeria, located in the south-west region of the Federal Republic of Nigeria. The firefighting centre is located at the East campus of the Institution, while the sensing location are two points, Microfinance bank (east campus) and New

Engineering Complex (west campus). The distances of these location to the firefighting centre was taken and provided as information for the microcontroller to process. These sensing centres were registered in the database of the system. The memory deployed allows for an expanded register of many more location for surveillance.

**B. Hardware Description**

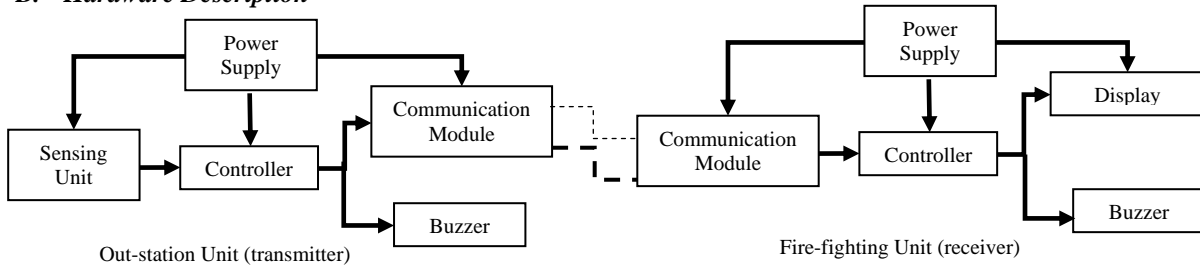

Figure 2: Overall system description

The block diagram of the system configuration is as shown in Fig. 2

**C. Sensing Unit**

The components of this unit are described in this section

**D. Smoke Sensing**

The MQ-2 semiconductor sensor for combustible gas was implemented for the activity. The device uses a low conductivity SnO<sub>2</sub> as its sensitive material. Its choice was driven by these characteristics [6];

- Good sensitivity to combustible gas
- Long life and low cost
- It's a simple device circuit

It responds to 300 – 1000 ppm combustible gas. It has two power inputs, the heater voltage (VH) and loop (test) voltage (VC). The heater voltage supply's the sensors certified working temperature, while the test voltage detects the voltage connected to the output of the sensor (load). Both voltages (VH and VC) can be provided from same power circuit. The MQ-2 has these settings, VH = 5V (dc), VC = 5 V (dc), detection setting (concentration) = 400 ppm (smoke).

It has six (6) pins, 4 is used to fetch signals, while the other two (2) are used to provide the heater a heating current.

**E. CO Sensing**

Detecting CO (carbon monoxide) was done using MQ-7 gas sensor. It does the detection at low temperature, so at CO gas detection, its sensitivity gets higher.

The MQ-7 was selected for this activity because of the following features;

- Good sensitivity to CO in wide range
- Long lifespan
- Low cost
- Simple drive circuit

It has these setting, VH = 5 V (dc) for high temperature, VC = 5 V (dc), detection setting = 20 ppm CO

**F. Communication Module**

The communication module implemented in the design is the SIM800L[7]. It is a quad-band GSM/GPRS module, operating on frequencies GSM850MHz, EGSM900MHz, DCS1800MHZ and

PCS1900MHz. It provides a multi-slot class 12/class 10 (optional) GPRS and supports GPRS coding schemes CS-1, CS-2, CS-3 and CDS-4.

SIM800L comprises of 68 pins pad and is designed with power saving feature, consuming current as low as 0.7 mA in sleep mode. It has the following features which provide for interfacing between the module and customers board;

One full modem serial port, one USB, audio channel, programmable general purpose input and output, SIM card interface, supports FM and one PWM.

The pin configuration of the SIM800L module is shown in Fig. 3

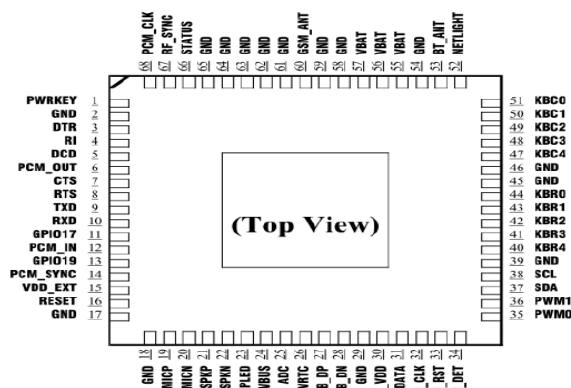

Figure 3: SIM800L module pin configuration

The SIM800L module has the following key features.

Table 1: Key features of SIM800L

Feature	Implementation
Power Supply	3.4 ~ 4.4 V
Transmitting power	Class 4 (2W) at GSM 850 and EGSM 900
GPRS Connectivity	Class 1 (1W) at DCS 1800 and PCS 1900 GPRS multi-slot class 12 (default) GPRS multi-slot class 1 ~12 (option)
Temperature range	Normal -40oC ~ +85oC Storage -45oC ~ +90oC
SMS	SMS storage: SIM card
SIM interface	Support SIM card: 1.8 V, 3V
Firmware upgrade	Main serial port or USB

The SIM interface complies with the GSM phase 1 specification and the new GSM phase 2+ specification for fast 64 kbps SIM card. The SIM interface is powered form an internal regulator in the module. The following are the pins for SIM card; 30-SIM\_VDD, 31-SIM\_DATA, 32-SIM\_CLK, 33-SIM\_RST and 34-SIM\_DET. The SIM800L module was used with an 8 pins SIM card holder, Molex 91228.

This module is deployed at both the transmitter (scene) end and the receiver (fire-fighting center) end of the system.

### G. Controller

The controller section was built on the Arduino microcontroller kit (arduinouno). It processes some set of instructions (software) to carry-out specific tasks. On-board of the microcontroller kit is the ATmega328 microprocessor. The microprocessor is a low-power CMOS 8-bit device based on the AVR enhanced architecture [8] and manufactured with Atmel’s high density non-volatile memory technology programmer. Moreover, it houses a 32 kilobytes of in-system programmable flash program memory, with read-while-write capabilities, 1024 bytes EEPROM, 2 Kbyte SRAM, 32 general purpose I/O lines, 32 general purpose registers, 10-bit ADC, to mention a few features. ATmega328 provides a highly-flexible and cost-effective solution to embedded control applications. The Arduino microcontroller possesses 14 digital I/O pins, 6 analog inputs, 16 MHz crystal oscillator, a USB connection, a power jack. It is powered by a 5 V (4.7 V – 5.3 V) dc supply. Uses a low to select a command register and a high to select a data register, low to write to register and high to read from register. The pin configuration and mapping is as shown in Fig. 4

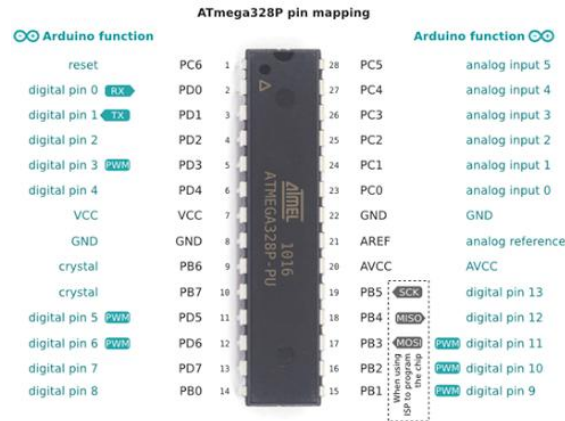

Figure 4: ATmega328 pin configuration and mapping

All sensor outputs were connected to the microcontroller through the ADC (analogue-to-digital converters) because the microcontroller only understands digital signals, while the outputs of the microcontroller connect to the communication module and buzzer.

The microcontroller is used at both the transmitter and receiver sections (scene location and fire-fighting centre).

**H. Power Supply**

The transmitter unit is powered via a dc source. A 9 V, 300 mA battery is implemented on the unit. An LED is provided to indicate the status of the power source. The receiver unit is powered through a dual system, dc battery and ac source. Appropriate components were chosen following a set of formulae. The schematic diagram of the transmitter and receiver units of the system are shown in Fig. 5 and 6 respectively

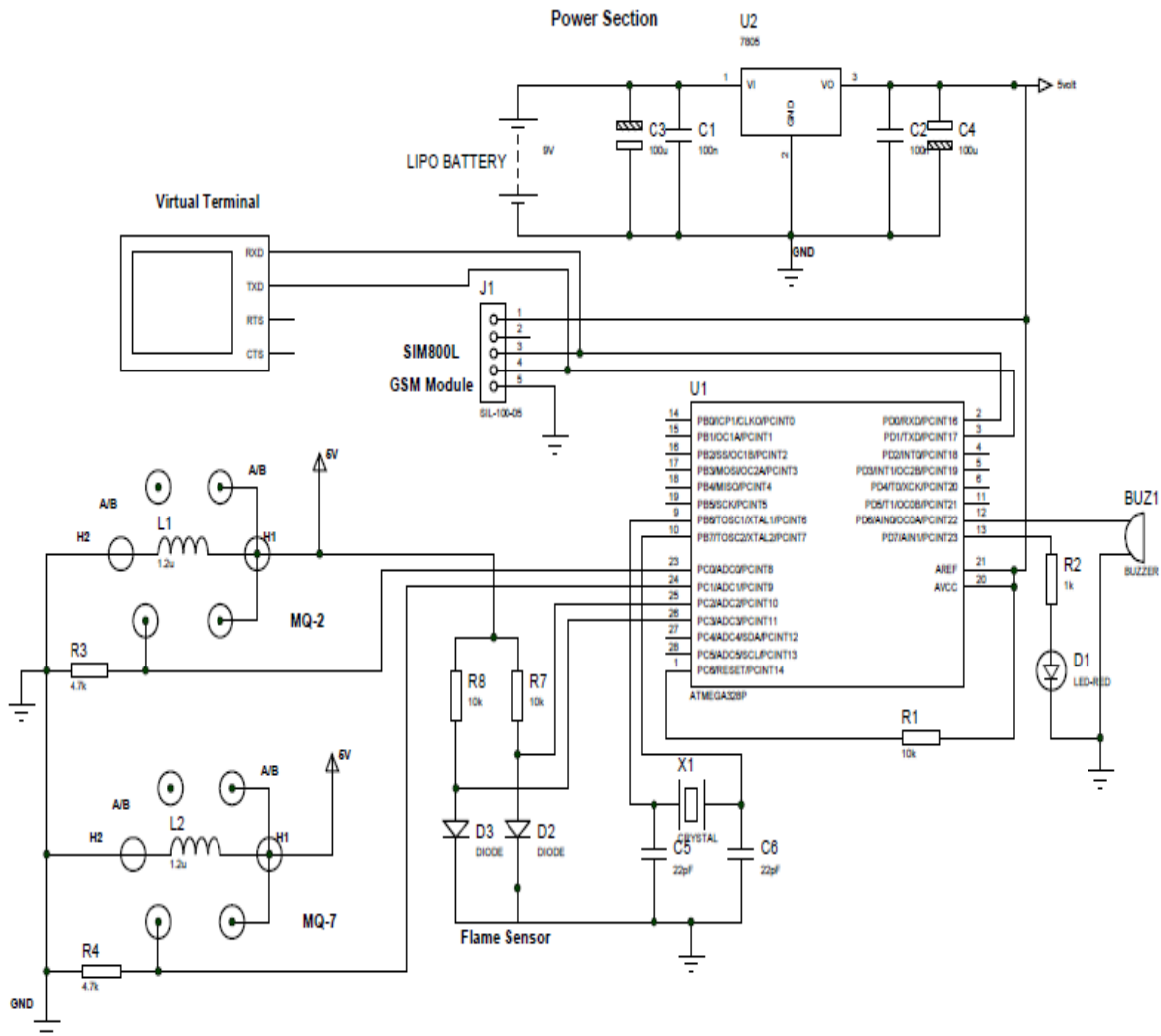

Figure 5: Fire monitoring transmitterschematics

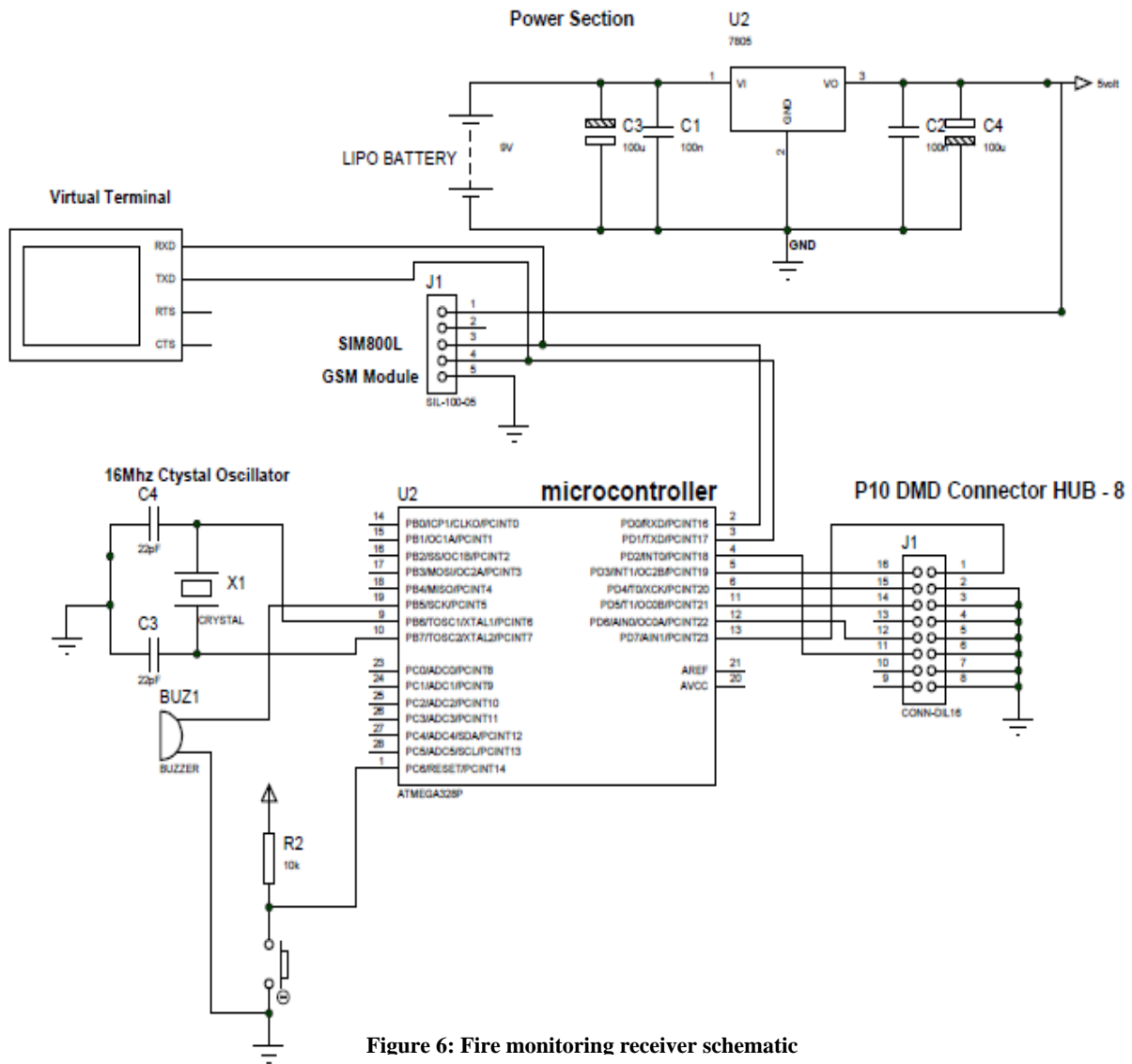

Figure 6: Fire monitoring receiver schematic

As stated earlier, the microcontroller follows a set of instructions to achieve the systems performance. This section describes the development of the set of

instructions governing the system operation. The activity involve two phases, namely, problem solving and implementation phases as shown in Fig. 7.

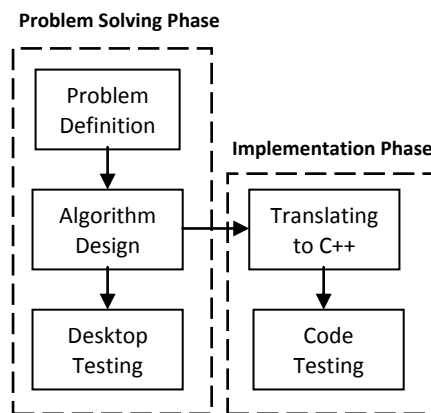

Figure 7: Software description.

A screenshot of the initializing code is as shown in Fig. 8.

```

File Edit Sketch Tools Help
fpi_dmd_receiver

//initialize TimerOne's interrupt/CPU usage used to scan and refresh the display
Timer1.initialize( 5000 ); //period in microseconds to call ScanDMD. Anything longer
Timer1.attachInterrupt( ScanDMD ); //attach the Timer1 interrupt to ScanDMD which goes to c
//clear/init the DMD pixels held in RAM
dmd.clearScreen( 0 ); //true is normal (all pixels off), false is negative (all pixels on)
dmd.setupBuffer(2);

    delay(5000);
//Send AT Command to GSM Modem

Serial.println("ATE0");
delay(1000);
Serial.println("AT+CMGF=1"); //Set the Modem to SMS Mode
delay(1000);
Serial.println("AT+CMGD=1,4"); //Set the Modem to SMS Mode
delay(1000);
Serial.println("AT+CNMI=1,2"); //Set the Modem to Indicate and Display New SMS
delay(2000);
}

void loop(void){
    // Serial.println("DMD should display now");

    if (dataAvailable) {
        if (westFlag){
            for (int z=0; z<4; z++){

```

Figure 8: Software initializing code.

#### IV. RESULT AND DISCUSSION

The schematic diagram shown in Figures 5 and 6 were constructed on the printed circuit board (PCB). The PCB is as shown in Fig. 9.

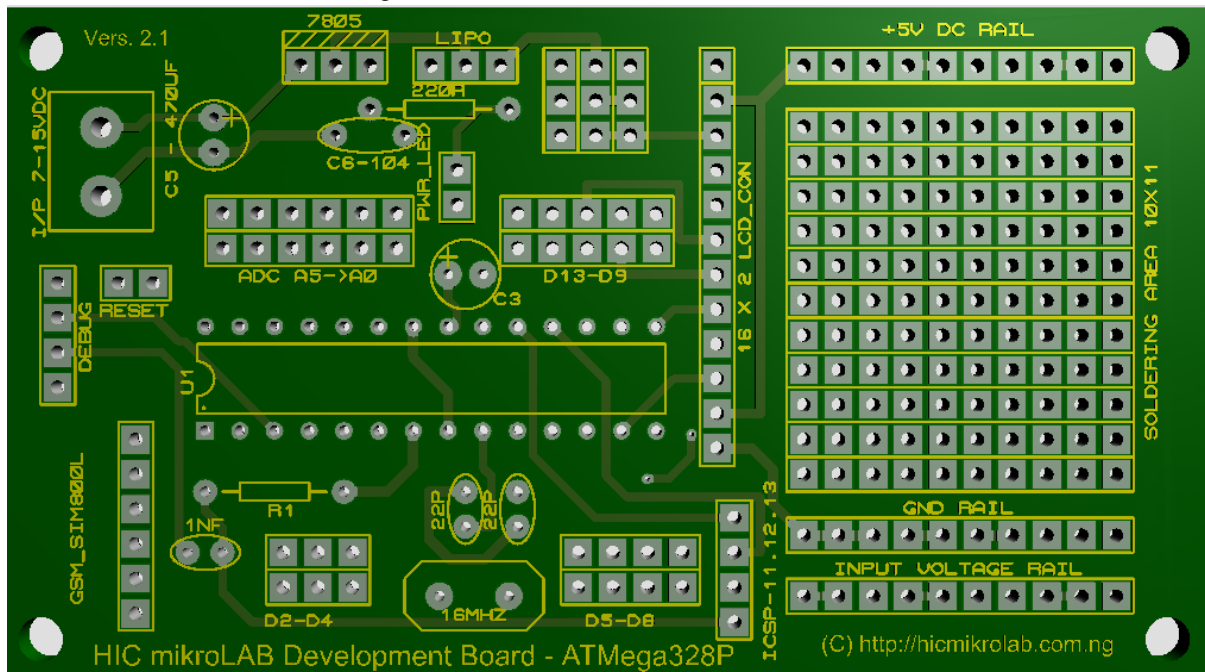

Figure 9: Circuit diagram PCB

The system was triggered with the required levels of smoke, CO, temperature and flame in one of the

registered locations (Micro-finance bank). The display at the fire-fighting centre is as shown in Fig. 10.



Figure 10: Fire-fighting Center Display

Fig. 10 reports an occurrence of fire at the micro-finance bank, 2 km away from the service centre. The various levels of the fire parameters are also provided. These information will help the fire-fighting office to prepare well for the putting off of the fire promptly.

## V. CONCLUSION

Prompt reporting of inferno will help in responding promptly to put out the fire, thus preventing or reduce any havoc as a result of the inferno. A system that will give a detailed information regarding an inferno incidence was developed in the proposed system. The information reported provides location, distance to service centre and time of occurrence of the inferno. This information will enhance quick response time and equip the fire-fighting service centre for the inferno put out.

## REFERENCES

- [1] S. Omahanna and A. Tinufa, "The Role of Design And Construction in Mitigating Fire Disasters in Housing in Nigeria," *Journal of Good Governance and Sustainable Development in Africa (JGGSDA)Print*) Iyaji, vol. 3, no. 31, pp. 2354–158, 2016.
- [2] E. K. Addai, S. K. Tulashie, J. Annan, and I. Yeboah, "The trends of fire outbreaks in Ghana and ways to prevent these incidences Trend of Fire Outbreaks in Ghana and Ways to Prevent These Incidents," *Safety and Health at Work*, no. March, 2016.
- [3] F. Derbel, "Reliable wireless communication for fire detection systems in commercial and residential areas," 2003 IEEE Wireless Communications and Networking, 2003. WCNC 2003., vol. 1, pp. 654–659, 2003.
- [4] Deepika and Yuvaraju, "Wireless Sensor Network Based on GSM for Automatic Fire Detection and Rescue System in," *International Journal of Engineering Research & Technology (IJERT)*, vol. 4, no. 11, pp. 543–545, 2015.
- [5] B. Son, Y. Her, and J. Kim, "A design and implementation of forest-fires surveillance system based on wireless sensor networks for South Korea mountains," *International Journal of Computer Science and Network Security (IJCSNS)*, vol. 6, no. 9, pp. 124–130, 2006.
- [6] T. Data, "MQ-2 Semiconductor Sensor for Combustible Gas," Pololu, p. 2, 2016.
- [7] SIMCom, "SIM800L Hardware Design V1.00." p. 21, 2013.
- [8] Atmel, ATmega328 / P. 2016.