

# Home Automation System for Rural Community

Fagbuaro, O. E. and Abdulhamide, I. G

Department of Electrical /Electronic Engineering, The Federal Polytechnic, Ilaro, Ogun State, Nigeria

## Abstract

Smartphones, computers, and laptops are more accessible than moving from one place to another to switch off various electrical devices inside various parts of our homes and offices. This paper discusses a centralized Zigbee wireless system that connects all the home or office electrical appliances and facilitates central control and monitoring of the status of their switches. The system is composed of a Java-based GUI that runs on a personal computer for giving a switch on/off command to a particular device, a Zigbee node for sending the command wirelessly, a C# programmed ATMEGA microcontroller for processing the received command and relays connected for executing the switching command. The system will enable a user, especially physically challenged, to remotely control electrical switches of electrical devices using their smartphones or computers.

**Keywords:** Zigbee, GUI, microcontroller, home appliances, C# programming

Date of Submission: 01-04-2022

Date of acceptance: 10-04-2022

## I. Introduction

Zigbee-based home automation can be a useful tool for the physically handicapped as well as old age persons because it can be implemented with a small initial cost to help them manage the switching of their home appliances with minimum effort (Jitendra, 2010). The same application can also be applied to optimize and economize energy consumption (Khusboo, 2016).

The extremely low power consumption requirements of the Zigbee (typically requires 2.7-3.6 voltage, 1 mW transmit power, 37 mA for transmitter/receiver, and 2.6  $\mu$ A in sleep mode) make it more suitable than Wi-Fi and Bluetooth for home automation use.

In our effort to provide a locally made product to solve our problem, we present a system that uses a personal computer, Zigbee modules, a microcontroller, and some relays to manage the ON/OFF switching of the home appliance. It does this function through a JAVA-based graphical user interface designed and installed on the computer.

## II. Related work

X10 is the earliest home automation technology that utilizes the home's existing mains wiring as the communications medium. It has the advantages of low cost and easy installation, plus the fact that the medium is already placed supplying power to the devices that one might wish to control. Unfortunately, the main provides an inhospitable environment for information signals due to noise from the grid and local interference caused by devices being switched on and off. Also, in instances where not all of a premises' power is supplied in the same phase, X10 cannot communicate over this phase gap without additional equipment. To overcome the noise problem, the bandwidth of the signal is restricted, but this results in a very low effective data rate of (~20bps) and limits the usefulness of the technology to basic control function. Furthermore, X10 is considered unreliable, labeled "plug and pray" technology on account of there being no acknowledgment of commands

INSTEON provides compatibility with existing X10 devices but improves communication by providing an additional network medium (RF), increasing the data rate to 2880 bps and adding reliability mechanisms like acknowledgments and retries. It also supports a much larger set of devices (65536 vs. 256) and commands (65536 vs. 16).

Saito et al., 2000 developed a home gateway system for interconnecting home networks consisting of IEEE 1394 AV network and X10 power line home automation network with the Internet. This provided remote access functions from the Internet for digital AV appliances like Digital Video Camera, Digital VCR connected to IEEE 1394 network, and home appliances like TV, desk lamp, electric fan connected to X10 controller.

The development of a Java-based home automation system via the World Wide Web helps the home appliances to control ports of embedded system board connected to PC-based server at home (Al-Ali, 2004).

(Chen Chao et al., 2009): Developed a remote wireless monitoring system for off-grid Wind turbines based on the GPRS and the Internet. The remote monitoring system is made up of three parts: controlling terminal, central monitoring computer, and communication network. The controlling terminal consists of microcontroller ARM7 LM3S1138, data acquisition module, and GPRS communication module WAVECOM Q2406B connected to ARM7 system using a serial port. GPRS module sends parameters relating to the wind turbine to the central monitoring computer. The client can access the central monitoring computer server through the Internet and know the parameters of different wind turbines.

### III. METHODOLOGY

#### 3.1 System architecture

The architecture of the system is shown in figure 2.0. It comprises two modules, the transmitter, and the receiver module. Two Zigbee modules are used in this application, one is connected to a PC and the other is connected to the microcontroller. The microcontroller can switch on/off devices with the help of a relay, according to the command given at the transmitter. As the user clicks any Button on the GUI at the transmitter end, proper data is sent to the ZigBee of the remote end. The ZigBee at the transmitter side will communicate to the ZigBee connected to the other side i.e. at the receiver device end. At the device end, the Zigbee will receive the data and feed it to the microcontroller. The microcontroller will check the data and turn ON/OFF the proper device with help of a relay connected at this end. It can also send a feedback message to the transmitter end and the display on the computer interface will be changed according to the status of the devices.

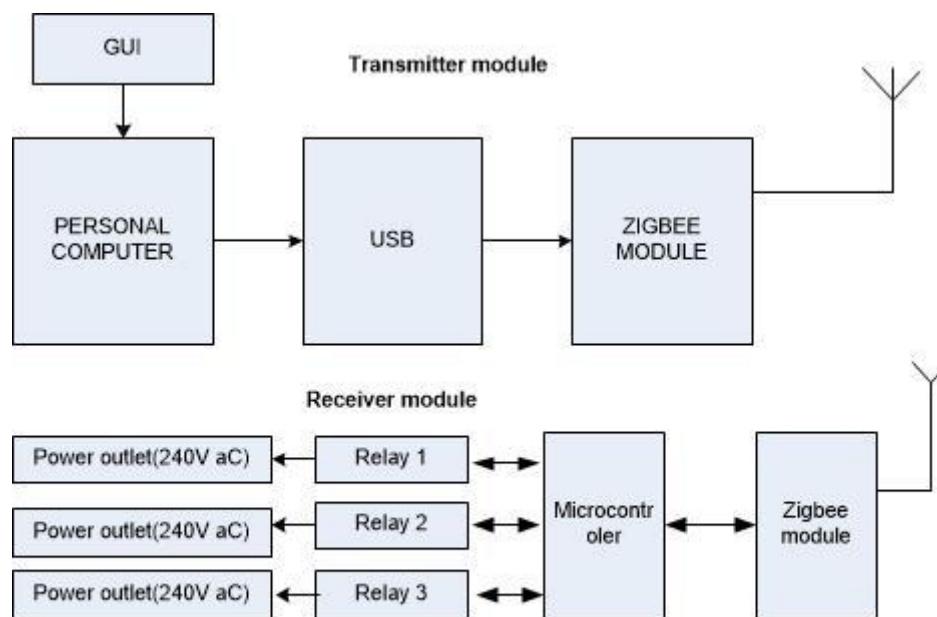

Figure 2.0 Block diagram of Transmitter and Receiver module

#### 3.2 Hardware components

- Personal computer
- Zigbee module
- Microcontroller and interfacing circuits
- AC/DC Adapter
- Relays

##### 3.2.1 Personal computer

A personal computer is used as a medium through which the on/off command signals is being sent to the various home appliances. It hosts an interface designed using the JAVA programming language. Figure 2.1 shows the diagram of the GUI. This GUI provides remote access to all the connected appliances.

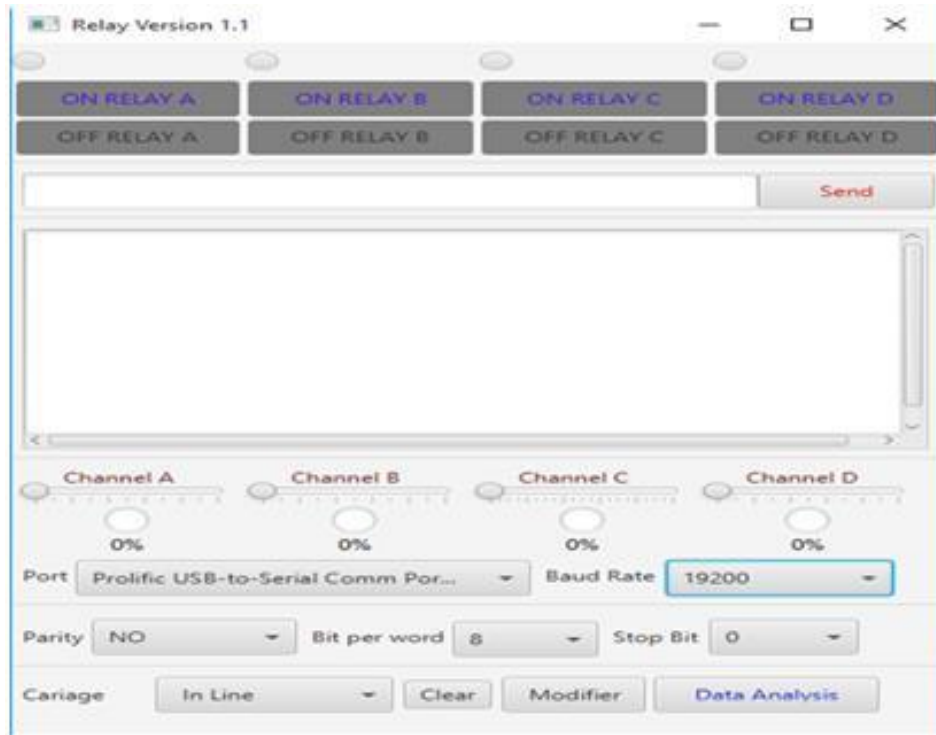

Figure 2.1 Graphical User Interface

3.2.2 Zigbee module

Zigbee is a wireless technology based on IEEE 802.15.4 which is extensively used in home automation systems. Zigbee technology provides a low data rate, low power, and low-cost wireless networking on device-level communication. IEEE 802.15.4 specifies physical and Mac layers. The Mac layer defines different network topologies, namely star, mesh and tree topology. This standard operates at three bands, 2.4 GHz, 868, and 912 MHz with data rates of 250, 20, and 40 kbps respectively. UART CC2530 is a Zigbee module developed by Waveshare, which adopts the CC2530 IC of TI as its main control chip. It has a long transmission distance. Zigbee network needs a minimum of coordinator and router (i.e. the transmitter and the receiver). The transmitter is connected to the PC using a Prolific USB cable. The specification of the Zigbee module is given in Table 2.0.

Table 2.0: Specification of the zigbee module

1	Feature	Descriptions
2	Voltage Range	3-5-5VDC
3	Current consumption	<30 mA
4	Transmission Rate	2.4 GHz
5	Maximum Transmission speed	3300 bps.
6	Transmission power	4.5 dBm
7	Ideal Transmission Distance	250m
8	Number of channels	16

3.2.3 Microcontroller

Atmega 328P was carefully selected as the microcontroller used for this home automation application. The microcontroller was programmed in the C# programming language. It serves as the heart of this project because it interprets a signal received and commands the relays to perform the ON/OFF operation accordingly.

Table 2.1: Specifications of the Microcontroller.

S/N	Features	Description
1	Manufacturer	Atmel
2	Part number	Atmega 328p-Pu
3	External oscillator	Up to 200MHz

4	A/D converter	10 bit, Six channels
5	Input/ Output pin	23
6	Timer	Two 8-bit/ One 16-bit
7	EEPROM Data	1 Kbytes
8	Flash Program Memory	32 Kbytes
9	Numbers of Pin	28

### 3.2.4 Relay

A relay is an electrically operated switch that opens and closes electrical contacts to switch ON/OFF any device connected to it. The microcontroller's output voltage (5 VDC) cannot derive an electrical device that requires 220 VAC input. The relay serves as an interface between the microcontroller and the electrical appliance connected to any of the outputs (A, B, and C).

Table 2.2: specifications of the Relay

S/N	Features	Description
1	Manufacturer	Songle
2	Number of Pins	5
3	Contacts	SPDT
4	Rated load	10A 250VAC, 10V 30VDC
5	Maximum Switching Current	10A
6	Maximum Switching Voltage	110VDC/ 250VAC
7	Coil power	0.45W
8	Contact Arrangement	C:1 (NO/NC)
9	Dimension	19×15×15 mm.

## IV. Performance test

The Zigbee home automation prototype designed and implemented consists of the transmitting and receiving parts. Once connected to a PC through a prolific USB cable, the transmitter module indicates double **red light** which signifies that the Zigbee module is powered. The receiving part is connected to an AC source using an AC/DC adapter and turned ON. The receiver module shows its connection to the transmitter by indicating a **green light**. When a command is being sent from the PC, a **red light** blinks on the transmitter and the receiver indicates reception of the sent signal by flashing **red light**. The normally open relay will close/open and there will be output. Through the GUI user can connect three different kinds of appliances directly to the receiver module and he can expand each of the three outputs by connecting a power strip to increase the number of connected devices connected to each.

- ❖ Relay A for a lighting system
- ❖ Relay B for controlling fan
- ❖ Relay C for the power sockets

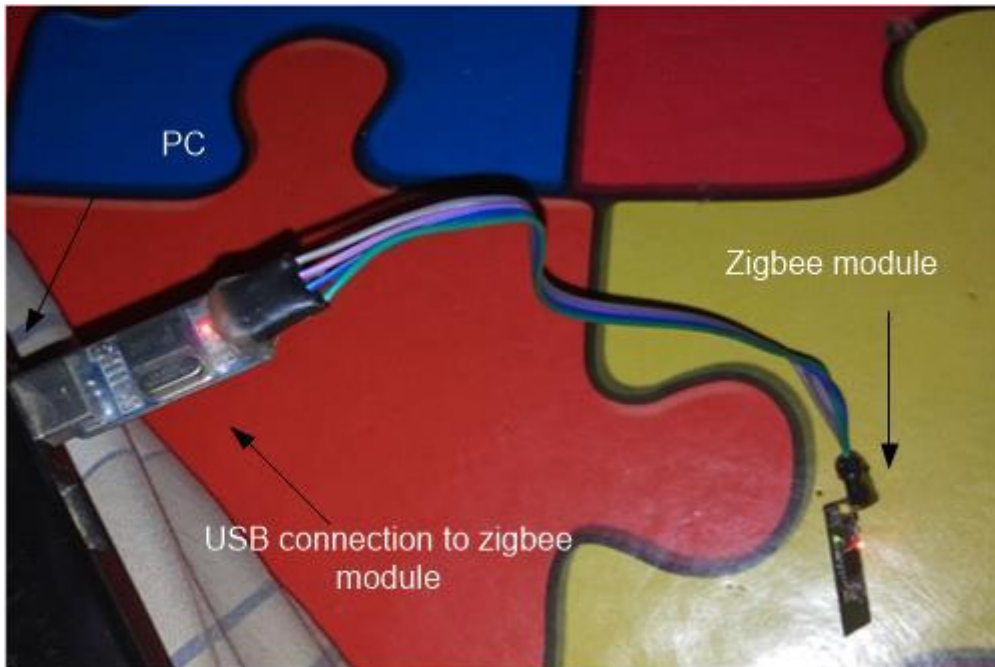
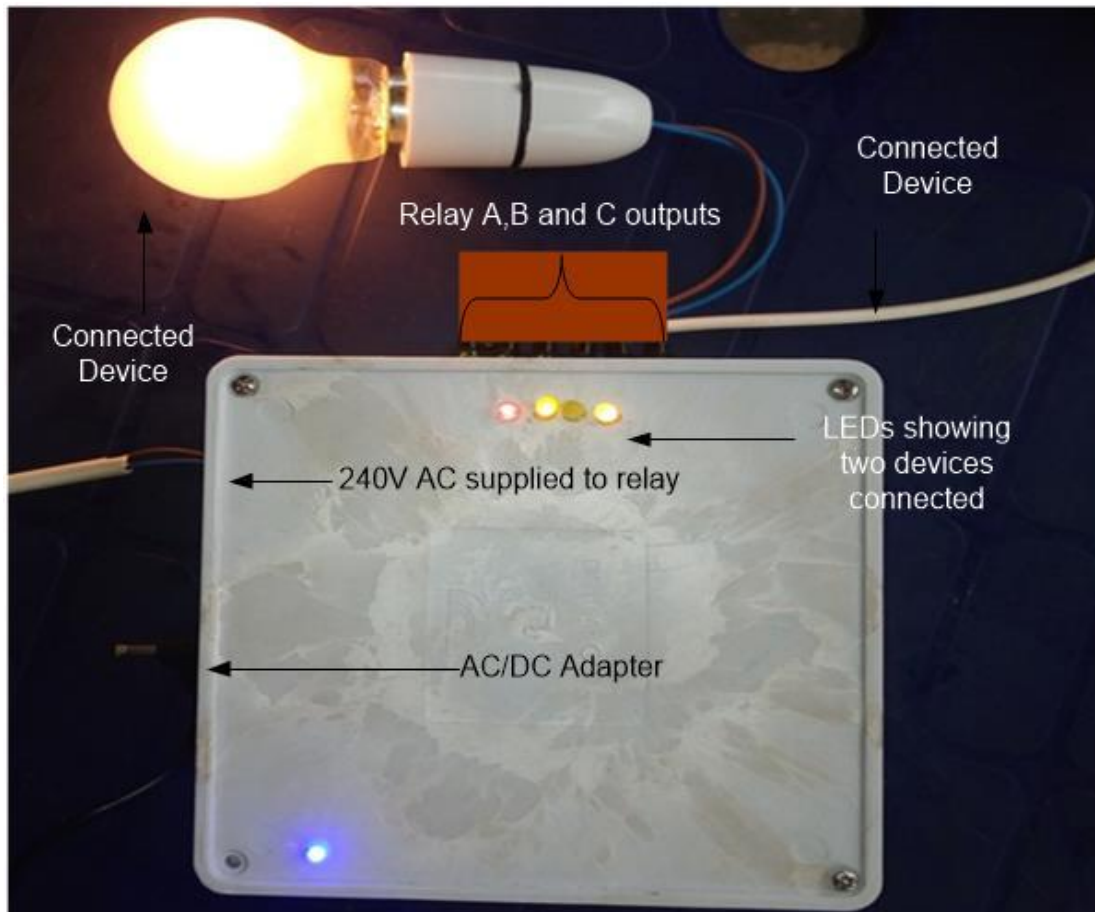

Fig 4.1 Transmitter module connected to a PC



Fig 4.2 Receiver module showing connection to transmitter



**Fig 4.3 the Receiver module connected to home appliances**

## V. Conclusion

This paper describes the solution to the problem of energy wastage experienced when a user finds it difficult to move around to turn OFF his or her home appliances at the right time from their connection point. It provides a centralized system that connects all appliances and a JAVA interface that provides access to the home appliances remotely.

## Reference

- [1]. Al-Ali, A. R. & Al-Rousan, M., (2004). Java-based home automation system, IEEE transactions on Consumer Electronics, (50)2, 498-504.
- [2]. Chen Chao et al. (2009). "The Remote Wireless Monitoring System Based on GPRS for off-Grid Wind Turbine," International Conference on New Trends in Information and Service Science, Beijing. 1150-1153.
- [3]. Jitendra R. Rana and S.N.Pawar, "ZigBee Based Home Automation", Research gate, 2010
- [4]. Khusboo Dhiman et al., "Zigbee Based Home Automation and Security System", International Journal of Engineering Science and Computing, Vol 6, Issue 4, PP 3921 -3925, April 2016
- [5]. Neha et al (2015), "Advanced Home Automation Using ZIGBEE Technology", International Journal of Computer Application, Volume 5- No. 5, PP 2250-1797, August 2015
- [6]. Saito et al, (2000). Home Gateway Architecture and its Implementation, IEEE International Conference on Consumer Electronics, 64(5), 194-195.

Fagbuaro, O.E, et. al. "An Analysis of Trip Generation and Distribution Models in the Tourism Regions of Morotai Island Regency." *American Journal of Engineering Research (AJER)*, vol. 11(04), 2022, pp. 09-14.