

**SJIF Impact Factor(2021) : 8.047**

**ISI I.F.Value : 1.188**

**ISSN (Online): 2455-3662**

**DOI: 10.36713/epra2013**

***EPRA International Journal of***  
**MULTIDISCIPLINARY**  
**RESEARCH**

***Monthly, Peer Reviewed (Refereed ) & Indexed International Journal***

***Volume - 7    Issue - 12    December    2021***



**I**  
**J**  
**M**  
**R**



**Chief Editor**  
**Dr. A. Singaraj, M.A., M.Phil., Ph.D.**

**Managing Editor**  
**Mrs.M.Josephin Immaculate Ruba**  
**Editorial Advisors**

1. **Dr.Yi-Lin Yu, Ph. D**  
Associate Professor,  
Department of Advertising & Public Relations,  
Fu Jen Catholic University,  
Taipei, Taiwan.
2. **Dr.G. Badri Narayanan, PhD,**  
Research Economist,  
Center for Global Trade Analysis,  
Purdue University,  
West Lafayette,  
Indiana, USA.
3. **Dr. Gajendra Naidu.J., M.Com, LL.M., M.B.A., PhD. MHRM**  
Professor & Head,  
Faculty of Finance, Botho University,  
Gaborone Campus, Botho Education Park,  
Kgale, Gaborone, Botswana.
4. **Dr. Ahmed Sebihi**  
Associate Professor  
Islamic Culture and Social Sciences (ICSS),  
Department of General Education (DGE),  
Gulf Medical University (GMU), UAE.
5. **Dr. Pradeep Kumar Choudhury,**  
Assistant Professor,  
Institute for Studies in Industrial Development,  
An ICSSR Research Institute,  
New Delhi- 110070.India.
6. **Dr. Sumita Bharat Goyal**  
Assistant Professor,  
Department of Commerce,  
Central University of Rajasthan,  
Bandar Sindri, Dist-Ajmer,  
Rajasthan, India
7. **Dr. C. Muniyandi, M.Sc., M. Phil., Ph. D,**  
Assistant Professor,  
Department of Econometrics,  
School of Economics,  
Madurai Kamaraj University,  
Madurai-625021, Tamil Nadu, India.
8. **Dr. B. Ravi Kumar,**  
Assistant Professor  
Department of GBEH,  
Sree Vidyanikethan Engineering College,  
A.Rangampet, Tirupati,  
Andhra Pradesh, India
9. **Dr. Gyanendra Awasthi, M.Sc., Ph.D., NET**  
Associate Professor & HOD  
Department of Biochemistry,  
Dolphin (PG) Institute of Biomedical & Natural Sciences,  
Dehradun, Uttarakhand, India.
10. **Dr. D.K. Awasthi, M.SC., Ph.D.**  
Associate Professor  
Department of Chemistry, Sri J.N.P.G. College,  
Charbagh, Lucknow,

ISSN (Online) : 2455 - 3662  
SJIF Impact Factor :8.047  
ISI.I.F. Value : 1.188  
DOI : 10.36713/epra2013



EPRA International Journal of  
**Multidisciplinary  
Research**

Monthly Peer Reviewed & Indexed  
International Online Journal

Volume: 7 Issue: 12 December 2021

Indexed By:



Published By :EPRA Publishing

CC License





# DESIGN AND CONSTRUCTION OF A MICROCONTROLLER BASED LIQUEFIED PETROLEUM GAS (LPG) LEAKAGE DETECTION SYSTEM

Adamu D.,<sup>1</sup> Suleiman, A. D.,<sup>2</sup>

Department of Computer Engineering, Federal Polytechnic Ilaro

## ABSTRACT

*Reducing the effects of greenhouse gas emissions has been a global problem; the implications of deforestation, coal and other fossil fuel burning have caused more harm than good, despite serving the purpose for which they were intended, namely energy provision. The hunt for renewable and clean energy has increased the use of liquefied petroleum gas (LPG), which is more efficient and clean in terms of greenhouse gas emissions, as well as the carnage. When any gas leakage is detected beyond the threshold of 390 PPM, this research effort designed and built an LPG leakage detection system using an ATmega328 to coordinate the processing and sensing of the gas leakage by the sensor MQ2. When this occurs, the technology intelligently activates the LCD, displacing the text emphasizing the LPG leaking while also triggering the buzzer to inform the user. During the research, the technology proved to be effective in identifying LPG leakage.*

## 1.0 INTRODUCTION

Liquefied Petroleum Gas (LPG) is a need in modern living. LPG is currently used mostly as a residential and industrial fuel. However, there is a growing tendency toward the use of LPG in a variety of applications, particularly in the vehicle industry. Liquefied Petroleum Gas (LPG) is an extremely flammable chemical that is made up primarily of butane, propane, isobutene, butylenes, and propylene mixes (LPG Gas Blog). It is utilized as a fuel for both home and industrial purposes. As a result of the mixing, the gas is a highly combustible material. It is an odorless gas in nature, but an odorant (e.g. Ethanthiol) is usually added to make leaks easier to detect (Health & Safety Authority 2021). People with a poor sense of smell may or may not react to minor gas leaks. As a result, gas leakage security systems have become a necessary technology for preventing gas leakage incidents. 2018 (Siddika & Hossain). The accumulation of a gas leak in an enclosed space, combined with air and an ignite source, is one of the primary causes of gas cylinder explosions. Various explosive gases found in nature, such as methane, LPG (propane or butane), or a welding gas, such as acetylene left by tradespeople, could also detonate the gas (Vasudev et al, 2016). Furthermore, inappropriate installation, ill-adapted cooking methods or practices by the user, insufficient care and irregular maintenance of equipment, and improperly stored at the end

consumer's residence are also key causes of LPG explosions (Clean cooking, 2019; Mohammed, 2020). LPG Gas leaks have been risen from 0.72% of all kitchen accidents to 10.74% of all of the kitchen accidents (Falohun & Abolaji, 2016). The exponential surge in the proportion of LPG consumers is to blame for this incremental patronage (Okonkwo, Obi & Idoko, 2020).

The tiny LPG cylinder weighing 5kg with the burner situated directly over the cylinder without the use of a rubber tube is considered to be safer than the one with a rubber tube, as the latter is prone to cracking, which can lead to leakage. We use LPG gas in most petrol/diesel vehicles due to rising fuel costs. The usage of LPG gas in a car or at home is quite dangerous. The state of the LPG gas cylinders used at home and elsewhere is the same. A few of the internal components of the sensor, such as a heater and a gas sensitive resistor, are employed to prevent failure and a false alert indication. When steam exceeds a particular quantity of gas, the alarm goes off. This device is meant to provide early warning of an issue in order to protect the public. In the fields of safety, health, and materials, LPG and gas sensors are used. This integrated device detects toxic gas and sends an SMS notice to users ( Shrivastava *et al.*, 2017). Toxic gases, combustible gases, and oxygen deprivation, among many other flammable gases, are easily detected by most current gas sensors. This type of device is

commonly used in enterprises to monitor manufacturing processes and can be found in places like oil rigs. To reduce the impact of dangerous gases on human health, gas leak detection devices are becoming increasingly important. Halder and Chatterjee (Halder & Chatterjee, 2019). Because of the severity of the carnage caused by an LPG gas explosion, the protection and security of people and

property is critical, which is why the drive to design and build an LPG gas explosion protection system exists. Monitoring system for gas leaks that uses an Arduino system to detect gas leaks as depicted in fig 1 and fig 2 respectively. In additional, this device may show the state of the leak and subsequently warn the user of potential danger via a display board and a buzzer.



Fig 1.a LPG Leaking out



Fig 1.b LPG Leaked Contact with an Ignition Source

The linked works will be detailed in Section II as they pertain to gas leak detection, while Section III will further dissect the methods used in the design and construction. Testing will be detailed in part IV, and the conclusion will be in section V.

## 2.0 LITERATURE REVIEW

Several studies on gas leakage detection techniques have been published in the past, either as part of research papers/technical reports on a specific leak detection method or on other gas-related topics. Raju and Rani (2008) presented an android-based autonomous gas detection system with an indicator robot. The proposed prototype illustrates a small mobile robot with a high potential for detecting gas leaks in hazardous environments. When a gas leak occurs in a specific location, the robot scans the data and sends it to an Android phone via an unlicensed wireless communication spectrum such as the Bluetooth protocol. The implementation of an android-based application that can accept data from the robot over Bluetooth is underway. The program notifies users when there is a gas leak and allows them to control the direction of the robot's movement using both text and voice instructions. Shyamaladevi et al. (2014) demonstrated the usage of ARM7 based automation, which is a high performance system for LPG refilling, booking, and leakage detection as an approach to mitigate the issue of gas leakage in their research. The

project is built on a modular architecture that makes it easy to analyze the source of leakage, which can come from the LPG cylinder booking unit, gas leakage monitoring device at the customer end, or the server system unit at the distributor end. MQ6 was strategically placed near the gas cylinder. When there is a gas leak, the sensor's resistance drops, increasing its conductivity, and equivalent pulses are transmitted into the microcontroller, which turns on the buzzer and exhaust fan at the same time. "EMERGENCY ALERT: LPG gas leakage identified in your home," the microcontroller sends a message. GSM module sends messages to preset cell phone numbers, which are shown on the LCD at the same time. In a similar vein, in order to aid humans in detecting gas leaks, Okonkwo et al. (2020) created a leakage detection system that combines the use of a MQ6 sensor with an Arduino-controlled SIM800L GSM module to send SMS alerts. Due to the huge potential for high sensitivity in detecting levels of LPG concentration caused by leakage part per million in order to protect the safety of people and property. Also because gas leakage is less than the preset threshold of 200 PPM, the system detects gas leakage but does not activate the LED or buzzer. As a result, when the values exceed the predefined levels, the microcontroller activates the buzzer and LED, signaling the magnitude of the leakage while also proclaiming the environment to be unsafe. Enalume & Obianke (2017) conducted a similar



study using the same type of sensor MQ6, but with a somewhat different method to addressing gas leakage issues. The system incorporates a PIC18F2520 to process the signal control received from the sensor, as well as a GSM module to send SMS to the user if the gas leakage exceeds the preset limit of 250 PPM. Furthermore, Mohammed (2020) designed a detector whose preset values fall within the standard range of 300 – 1000 PPM to avoid the disastrous problems caused by gas leakages. The efficiency of the approach is the ability to detect gas leaks levels above the preset standard within 2 seconds after the start of the leak and automatically switching off any system that might further ignite any form of combustor. Rawat et al. (2014) published a paper on the identification and monitoring of economic fuels such as petroleum and liquid petroleum gas. Arduino was used in this project as the microcontroller. The ATmega328 is a 32-Kbyte microcontroller on a single chip (with 0.5 Kbyte which is occupied through the boot loader). It also has SRAM and EEPROM, which can be written and read using the EEPROM library, as well as I/O pins, an AVR microcontroller chip, a power jack, a USB connection, an ICSP (In-Circuit System Programming) header, and a reset button. It is simply connected to a computer with a USB wire. The Arduino's clock speed is 8 MHz, which means it can complete a task faster than other processors or controllers. The ATmega 238 chip never stops clocking at 8 MHz, regardless of what code is running; hence, its current consumption is basically independent of the code that is executed. MQ5 is the sensor that was proposed in this paper. Its advantages include excellent CO/combustible gas sensitivity, high sensitivity to methane, propane, and CO, long life and low cost, and a simple drive circuit. The wrapped MQ5 has six pins: four for fetching signals and two for providing heating current. The sensor may work with voltages ranging from 5 to 12 volts AC or DC. For this project, a 5V supply voltage was employed. When the sensor is turned on, the output is ordinarily HIGH, but when gas is detected, it becomes LOW.

### 3.0 METHODOLOGY AND MATERIALS

#### 3.1 Design Analysis

There are two parts to the system: hardware and software. The hardware design consists of a stand-alone embedded system based on an 8-bit microcontroller (ATmega328) that serves as a controlling unit for the system's overall functionality, and a sensor (MQ2) that is primarily composed of SnO<sub>2</sub> and has a reduced conductive property. When the Sensor detects a progressive increase in the flammable gas concentration, its conductivity increases. The MQ2 sensor's dynamic functioning, particularly its high level of sensitivity in the detection of various gases, makes it flexible. The sensor's default setting was 390 PPM. The buzzer, on the other hand, functions as an alarm. When MQ2 detects a gas leakage in the environment and the readings are over the preset value of 390 PPM, it signals the ATmega328 to give a digital output 1; otherwise, when the leakage detected is less than the preset, a digital output 0 is signaled out. Programming in the ATmega328 IDE environment is part of the software. The sensor will report the corresponding gas value to the microcontroller whenever the system detects the presence of LPG. The MQ2 sensor output 1 is received as a digital input to the microcontroller's pins. The microcontroller will trigger the Buzzer and display "GAS IS LEAKING" on the LCD based on the condition of the sensor at that particular time, assuming it detects gas leakage and signals the sensor output as High. However, if the MQ2 sensor readings indicate that the output is low, the microcontroller will not trigger the buzzer and instead turn on the LCD, which will display "NO GAS LEAKAGE."

#### Flow Diagram

A flow chart guided the program that was written into the ATmega328 microcontroller. As shown in Figure 3, the system initially initializes, then scans for the presence of gas, reads sensor values, and sends them to the controller for any necessary decisions.

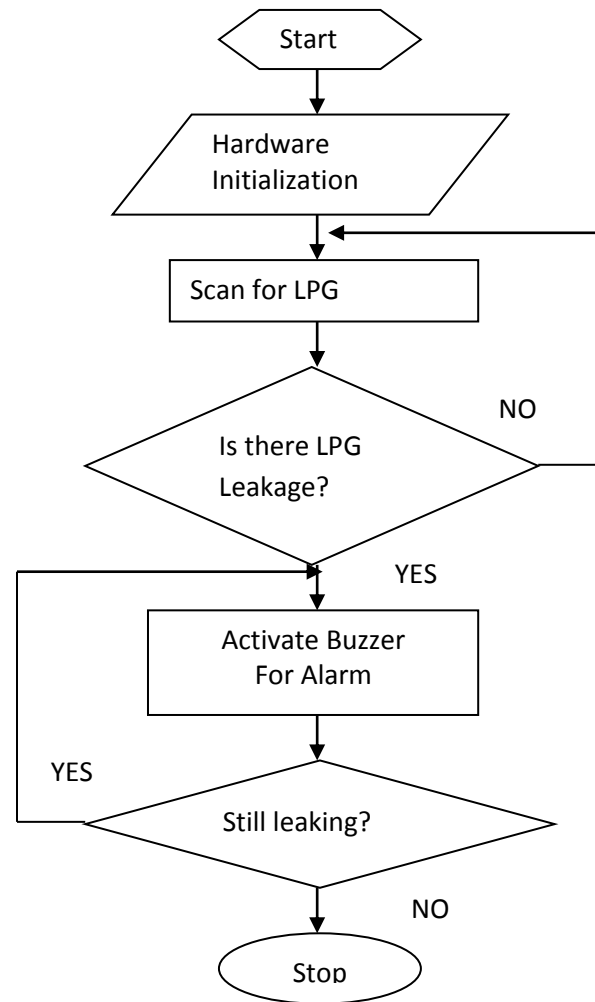

**Figure 3: System Flowchart**

The system was created to be installed in both public and private locations, such as businesses, offices, and houses. Furthermore, with the aid of a sensor intended for the purpose, it is designed to monitor and identify gas leaks within a limited setting. The system will detect gas leakage for a specific place once it is properly setup and implemented by following the steps below:

- Scan for the presence of gas and display a status on LCD: Once activated, the device will automatically monitor the surroundings for gas and relay the results to the LCD display screen. If there is no gas available to detect, the screen will display "NO GAS LEAKING."

If there is a gas leak, however, the message "GAS IS LEAKING" will appear on the screen.

- Alarm for action: If the sensor detects gas leaking in a room or elsewhere within the device's coverage area, it immediately displays a notification on the screen and activates the Buzzer (Alarm).
- Resetting the system: If no action is made on the gas leak or the gas sensor does not detect any gas leakage, the alarm will be deactivated and the system will continue to search for gas. Figure 4 depicts the system circuit arrangement.

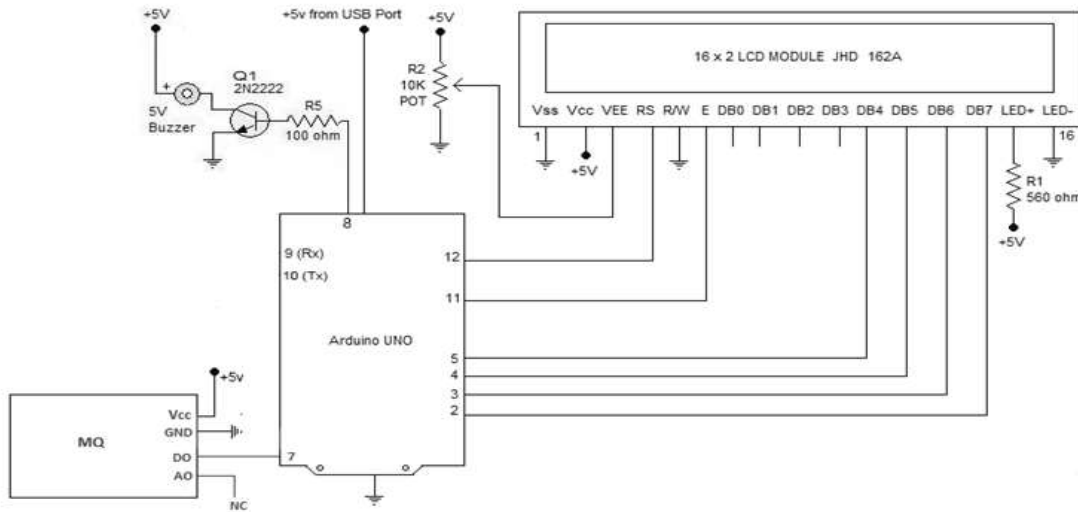

Figure 4: System Circuit Diagram

**LPG Hardware Configuration**

Table 2: Pins configuration of the Components

<u>Gas sensor (MQ-2)</u>	<u>Arduino Uno</u>	<u>Display LCD (16x02)</u>	<u>Arduino Uno</u>
<u>Pins</u>	<u>Pins</u>	<u>Pins</u>	<u>Pins</u>
VCC	5V	VCC	5V
GND	GND	GND	GND
D0	.....	RS	digital---2
A0	A0	R/W	GND
		E	digital---3
<b>Buzzer - terminals</b>	<b>Arduino Uno - Pins</b>	DB0	-----
Positive (+ve) terminal	digital ---8	DB1	-----
Negative (-ve) terminal	GND	DB2	-----
		DB3	-----
<b>Battery (9V) -terminals</b>	<b>Arduino Uno -Pins</b>	DB4	digital---4
Positive (+ve) terminal	Vin	DB5	digital---5
Negative (-ve) terminal	GND	DB6	digital---6
		DB7	digital---7
		LED (A) +	5V
		LED (K) -	GND

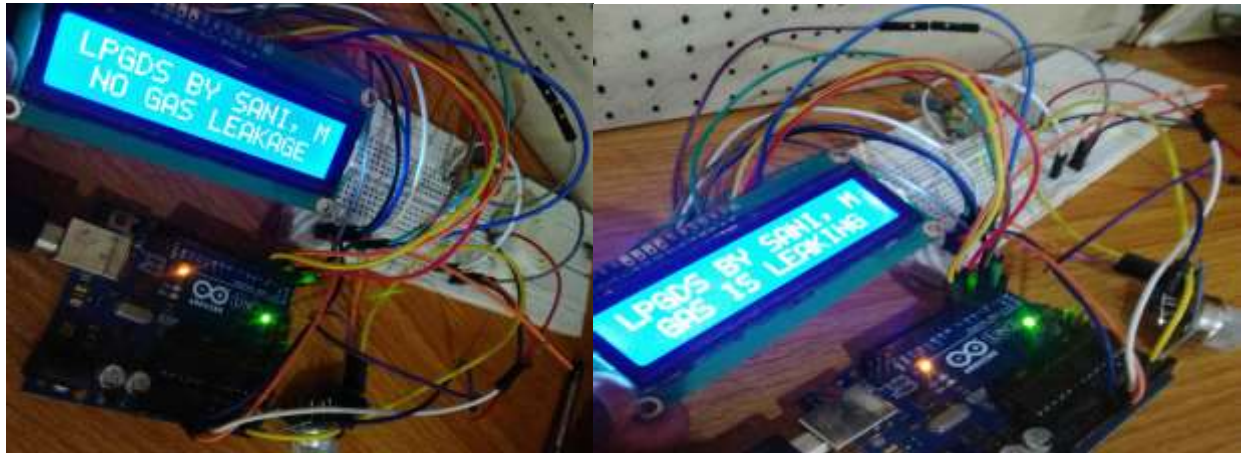

Figure 5: System Hardware Layout a) No Gas detected b) Gas is presence.

### LPG Software Programming

After completing the design and hardware setup, you'll need a set of instructions (or a program) to control the microcontroller on the Arduino chip. The software was created in the Arduino IDE using the

built-in C language. The instructions (codes) are written in the Arduino IDE, compiled, and then uploaded to the ATmega328 microcontroller. Figure 6 shows the code that was utilized in this project.

```
SaniM | Arduino 1.8.5
File Edit Sketch Tools Help

SaniM
7 Serial.begin (9600);
8 lcd.begin (16,2);
9 lcd.clear();
10 lcd.setCursor(0,0);
11 lcd.print("LPGD System By Sani,M. 19/STP/42001");
12 pinMode(8,OUTPUT);
13 pinMode(A0,INPUT);
14
15 ]
16
17 void loop() {
18
19   data=analogRead(A0);
20   Serial.print("Analog Data =");
21   Serial.println(data);
22   delay(100);
23
24   for (char positionCounter=0; positionCounter <16; positionCounter++){
25     lcd.scrollDisplayLeft();
26     delay(500);
27   }
28   if (data<=570){
29     digitalWrite(8, LOW);
30     lcd.setCursor(1,1);
31     lcd.print("NO GAS LEAKAGE");
32
33     delay(200);
34   }
35 }
```

COM9 (Arduino/Genuino Uno)

```
Analog Data =:594
Analog Data =:595
Analog Data =:594
Analog Data =:595
Analog Data =:597
Analog Data =:599
Analog Data =:600
Analog Data =:601
Analog Data =:608
Analog Data =:608
Analog Data =:615
Analog Data =:616
Analog Data =:614
Analog Data =:612
Analog Data =:611
```

Autoscroll

Figure 6: Program code



#### 4.0 DISCUSSION OF RESULT

A portable gas leakage monitoring and detection equipment was conceived and built successfully as part of this research project. The system is made up of four components: a power source, a gas sensor detector, a microprocessor, and an alarm (Buzzer). Before soldering the units on the board, each component was tested to ensure that it was in good working order. While the modules were being configured, the entire system was tested, with a gas sensor detecting the presence of gas leaks and sending the analog signal value to the ATmega328 controller via its analog input connection. The microcontroller analyzed the signals, displayed "Gas is Leaking" on the LCD, and turned on

the security system alert (Buzzer) that would draw nearby people's notice and prompt them to take appropriate action.

#### 4.1 PRESENTATION OF RESULT

The Microcontroller Circuit, Power Supply, GAS Sensor Module, and Buzzer make up the entire gadget. The GSM Module receives power from the power supply. As soon as the MQ-2 Gas Sensor detects any gas leakage from the storage, the sensor's output drops. The microcontroller detects this and turns on the LED and buzzer. The microcontroller continues to send "GAS LEAKAGE" messages to the Display Module. Figure 7 depicts the entire mechanism.



Figure: 7 Complete LPG Detection Device

#### TESTING OF RESULT

With a 5 volt power supply, Arduino will be operational. When the system is turned on, the sensor will detect gas leakage and display "NO GAS LEAKAGE" on the display if there is none. If the gas is not leaked, the next two procedures will be taken.

Step 1: The microcontroller sends a signal to the display, which displays a gas leakage notification.

Step 2: When the first step is accomplished, the Buzzer will emit a signal.

#### 5.0 CONCLUSION

The ATmega323 microcontroller was used to effectively develop a gas leakage detector that can detect LPG leaking in specific areas such as laboratories, kitchens, and industries for safety reasons. In addition to detecting LPG leaks, the sensor can also

detect other dangerous gases. Future research on this project could include the use of a GSM Module to send a gas leaking message to the user's cell phone through SMS. There are numerous sorts of weaknesses in developing and producing a prototype system, both from the system planning and the equipment that has been created; it requires development, including the addition of a buzzer output that can notify the surrounding area if there is a gas leak, add a controller function, such as an electrical switch, so that if a gas leak happens, it will automatically turn off some appliances, and finally, make it a GSM-based system so that you can monitor and control data in greater detail and in real-time.



## REFERENCES

1. Clean cooking, (2019):  
<https://www.cleancookingalliance.org>
2. Enalume, K. O., & Obianke, S.K.,(2017): "Design and Implementation of an Efficient LPG Leakage Detector", *International Journal of Latest Engineering Research and Applications (IJLERA)*, Vol.2(06) pp. 20 – 26. ISSN: 2455 - 7137
3. Falohun A.S., Oke A.O., Abolaji B.M. (2016). "Dangerous gas detection using an integrated circuit and MQ-9". *International Journal of Computer Applications*; Vol.135(7).
4. LPG Gas Blog (2021):  
<https://www.elgas.com.au/blog/453-the-science-a-properties-of-lpg/>
5. Halder, M. and Chatterjee S (2019). "Microcontroller Based LPG Gas Leakage Alert System" *International Journal of Engineering and Applied Sciences (IJEAS)* Vol. 6(2). 29-31
6. Health & Safety Authorites (2021):  
[https://www.hsa.ie/eng/Topics/Liquid\\_Petroleum\\_Gas\\_LPG/](https://www.hsa.ie/eng/Topics/Liquid_Petroleum_Gas_LPG/)
7. Raju, C.M and Rani, N.S. (2008) "An android based automatic gas detection and indication robot". *International Journal of Computer Engineering and Applications*. 2014. Vol. 8(1) 58-70.
8. Mohammed M. K., (2020): "Sensor-Based Gas leakage Detector System" *Proc. of the 7th Electronic Conference on Sensors and Applications*, 15 – 30 November, 2020 pp. 1- 6.
9. Okonkwo P. A., Obi, A.I., & Idoko S. O., (2020): "Design and Construction of Cooking Gas (LPG) Leakage Detector", *Proc. of the 2020 Sustainable Engineering and Industrial Technology Conference, Faculty of Engineering University of Nigeria, Nsukka, 6th -10th July 2020*, pp. 1-6
10. Shrivastava, A., Prabhaker, R. and Kumar, V.(2013). "GSM based gas leakage detection system." *International Journal of Emerging Trends in Electrical and Electronics*, vol. (2) 42-45.
11. Shyamaladevi, S., Rajaramya, V.G., Rajasekar, P. and Sebastin A.P (2014). "ARM7 based automated high performance system for lpg refill booking & leakage detection". Vol. 3(2).
12. Siddika, A., and Hossain, I. (2018). "LPG Gas Leakage Monitoring and Alert System using Arduino" *International Journal of Science and Research (IJSR)* Vol. 7(42). 1734-1737
13. Vasudev, Y. Akhilesh, S., Sofiya, B., Vipin, K., Ubais, A., Suraj, K. (2016) "A Review on Microcontroller based LPG Gas Leakage Detector" *Journal of VLSI Design and Signal Processing*. Vol. 2(3) 01-10