



Evaluation of Sprinkler Irrigation Evaporation Losses in Ilaro, Ogun State, South Western Nigeria

Samuel Dare OLUWAGBAYIDE^{1a*} Olugbenga FASANU^{1b} Ajayi Johnson OLORUNTADE^{1c}

^aDepartment of Agricultural and Bio-Environmental Engineering, Federal Polytechnic, Ilaro, Ogun State, NIGERIA

^bDepartment of Agricultural Education, Federal College of Education (Technical), Akoka, Lagos, NIGERIA

^cDepartment of Agricultural and Bio-Environmental Engineering, Rufus Giwa Polytechnic, Owo, Ondo State, NIGERIA

(*): Corresponding author, samuel.oluwagbayide@federalpolyilaro.edu.ng

ABSTRACT

Under the prevailing climate change the world is currently facing, efficient irrigation water management is essential to ensure food security, especially in countries with similar climate to Nigeria. Hence, this study was undertaken at the Research Farm of Federal Polytechnic, Ilaro, Ogun State, Nigeria to evaluate evaporation losses during sprinkler irrigation between March and July 2019. Experiments were performed using 360° rotating sprinkler and single nozzle of diameter 3 mm, while due cognizance was taken of the prevailing climatic conditions. Three operating pressures, namely, 50 kPa, 100 kPa and 150 kPa, representing low pressure, medium pressure and high pressure, respectively, were used. The results showed that operating pressures influence droplet sizes, droplet heights and flow rate during the experiment. In addition, it was observed that at operating pressures of 50 kPa, 100 kPa and 150 kPa, mean percentage of evaporation losses were 8.88%, 13.21% and 16.46%, respectively, indicating that evaporation losses increased with increasing operating pressure. Further analysis showed that percentage evaporation losses increased at higher relative humidity, thereby emphasizing the predominance of air temperature and wind velocity as climatic variable influencing sprinkler evaporation losses. The relationship between wind velocity (V_w) and air temperature (T_a) and to predict evaporation losses (E) was a function of $E = 7.968V_w + 0.393T_a - 19.977$. Therefore, it was concluded that, both climatic factors and operating pressures influence the rate of evaporation losses during sprinkler irrigation, adequate attention should be paid to variation of climatic variables since sprinklers are sold with their specified operating pressures.

RESEARCH ARTICLE

Received: 10.11.2020

Accepted: 06.01.2021

Keywords:

- Sprinkler irrigation,
- Evaporation losses,
- Climatic factors,
- Droplet sizes,
- Droplet heights,
- Flow rate

To cite: Oluwagbayide SD, Fasanu O, Oloruntade AJ (2021). Evaluation of Sprinkler Irrigation Evaporation Losses in Ilaro, Ogun State, South Western Nigeria. Turkish Journal of Agricultural Engineering Research (TURKAGER), 2(1): 47-59.
<https://doi.org/10.46592/turkager.2021.v02i01.004>

INTRODUCTION

The world all over currently faces the challenges of climate change such that it has become extremely difficult to rely on rain-fed agriculture to provide solutions to the problems of food insecurity, especially in Nigeria where population growth is at its alarming rate. [McJannet *et al.* \(2013\)](#) stated that under inadequate water supply from natural sources and food security concerns aggravated by growing population and climate change pressures, proficient use of available water supplies has become imperative. In this regard, there is the need to think beyond the natural water supply (rainfall) and embrace options through which water can be artificially supplied (irrigation) to the field when the need arises. However, the process of irrigation water application is also faced with the challenges of evaporation losses. Although water losses in form of evaporation can be of little percentage, [Phogat *et al.* \(2016\)](#) stated that water losses through evaporation during irrigation could be huge. Consequently, there is the need to pay adequate attention to such losses, given the prevailing global competing demands for water.

Many methods of irrigation exist among which is sprinkler system of irrigation. In this system, the application of water to the land takes the form of a spray. This system is becoming the favorite method owing to increasing paucity of water available for irrigation around the world especially in arid and semi-arid regions like Nigeria ([Uddin, 2010](#)). Moreover, a sprinkler irrigation system is less susceptible to erosion, not easily affected by topography and can be easily adapted for fertilizer application (fertigation), amongst other benefits. Nevertheless, efficient management of water during irrigation practice including sprinkler system requires adequate knowledge of water application efficiency ([Dasila *et al.*, 2016](#)). [Irmak *et al.* \(2011\)](#) suggested that as available water resources turn out to be uncommon, more prominence is given to efficient use of irrigation water for ultimate economic return and water resources sustainability. This means that all losses associated with irrigation water including spray droplet evaporation, soil evaporation, water use by unwanted plants, amongst others, should be monitored and minimized to ensure system efficiency. However, water application efficiency of a sprinkler system is majorly controlled by the amount of drift losses and evaporation ([Bavi *et al.*, 2017](#)). This is even as [Stambouli *et al.* \(2013\)](#) noted that gross sprinkler evaporation losses can be enormous to the extent of reducing irrigation application efficiency. Therefore, there is a need for an adequate understanding of the water losses under sprinkler irrigation systems to achieve greater sprinkler efficiency.

Meanwhile, sprinkler efficiency depends on the losses that occur during and after any sprinkler operation. Losses from sprinkler account for a large magnitude of portion of water discharged by the sprinkler. These losses are accounted for as the difference between the volume of water exiting the nozzle and water volume obtained with a grid of catch-cans ([Kadam and Deshmukh, 2011](#)). The amount of water losses to drift losses and evaporation depend on the prevailing operating and climatic situations. Many scientists have worked on various aspects of evaporation losses in sprinkler irrigation systems. For instance, [Christiansen \(1942\)](#) studied evaporation losses by making use of the catch-can method and discovered that losses varied from values of 19 to 42%. Nevertheless, no attempt was made to correlate the losses with any climatic variables. Sprinkler irrigation losses are approximately proportionate to operating pressure and

wind velocity and inversely proportionate to nozzle size and relative humidity of the air ([Frost and Schwalen, 1955](#)).

Moreover, evaporation and wind drift losses increased with the increased in the height of sprinkler's riser ([Strong, 1961](#)). Also, evaporation and wind drift losses varied from 3.4 to 17% while 36% of the losses was due to wind drift ([Kraus, 1966](#)). In the study conducted by [Sternberg \(1967\)](#), he found out that 60% of the total losses were wind drift losses. [Kadam and Deshmukh \(2011\)](#) studied the effect of nozzle size on evaporation and drift losses using a mini-sprinkler and reported that evaporation and drift losses increased with small nozzles but decreased with large nozzle size. [Bavi *et al.* \(2017\)](#) worked on the evaporation losses from sprinkler irrigation under various operating conditions in the western south of Koran. The results obtained from the study indicated that vapour pressure deficit and wind velocity were the most noteworthy factors influencing evaporation losses. The study further established exponential relationships between the evaporation losses, vapor pressure deficit and wind velocity.

Many methods have been adopted to evaluate evaporation losses in the field. Most conventional methods adopted in the field involve the use of volumetric determination of water obtained with the catch-cans. However, the fundamental challenge of this technique is that it estimates droplet evaporation loss during irrigation majorly from the evaporated water in the catch-cans. Additionally, accurate measurement of water that reaches the ground is also very difficult especially in windy conditions which increases the sampling area due to drift. [Kohl *et al.* \(1987\)](#) reported that measurements using catch-cans commonly have experimental errors. To avoid these difficulties of measurement, wind drift loss was often included with evaporation losses ([McLean *et al.* 2000](#)). [Jensen \(1980\)](#) pointed out that investigators have applied corrections to account for these errors, but accurate measurements are difficult to achieve. Recent studies conducted by [Uddin *et al.* \(2013a; 2013b\)](#) showed that the advanced eddy covariance (*ECV*) technique provides a better measurement of total evaporation losses during sprinkler irrigation. The technique also provides additional benefits of identification of the components of total evaporation with some other additional measurements.

Notwithstanding the foregoing studies, information on evaporation losses during irrigation in Nigeria, especially the sprinkler system, is sparse. Presently, there are reasons to suggest that the irrigation potential of the country has not been fully explored, Accordingly, only 45% of the total irrigation potential of the 2.0 million ha, is under irrigation, while the northern part of the country with very low average annual rainfall shares about 70% of the total irrigation potential, about 20% is spread over the humid south with the balance in the central and western plateau areas. FAO-Aquastat (2016) noted that, of the 293 117 ha area of land equipped for irrigation in Nigeria, only about 218 840 ha (75%) of its was actually irrigated. However, there is scarcity of information in respect of the use of sprinkler or any other systems of irrigation in the country.

Nevertheless, with high rainfall variability and climate change coupled with the challenges of adequate food production to meet the growing population and the need for economic diversification, embracing irrigation using the sprinkler system has become imperative. Nonetheless, any adoption of sprinkler irrigation system without adequate information on the inherent evaporation losses cannot be efficient. Thus, the present study is aimed at evaluating the magnitude of sprinkler evaporation losses under varied operating pressures and climatic conditions in Ilaro, south western Nigeria.

MATERIALS AND METHODS

The experiment was carried out at the Research Farm of the Federal Polytechnic, Ilaro, Ogun State, Nigeria between 1st March and 31st July, 2019. Ilaro as shown in Figure 1, is the headquarters of Yewa South Local Government Area of Ogun State, Nigeria. The town is located on latitude 6°53'11.5" N and longitude 3°1'13.8" E and at an altitude of 89 m above sea level. Also, Ilaro has a population figure of about 46 999 according the National Population Commission [NPC \(2006\)](#) census. It lies in the rain forest zone with a mean annual rainfall of between 1100 and 1300 mm and with an average temperature of 27.5°C. The onset of rainfall is usually March/April while cessation is around October/November. The pattern of rainfall in Ilaro is bimodal with the first peak occurring in June to July, and the second in September while in August there is a short dry spell known as the “august break”. The relative humidity ranges between 85 and 100% during the rainy season and less than 60% during the dry season period. At least 60% of the population of Ilaro is engaged in farming with cassava, maize, yam, and other grain crops being their major agricultural products.

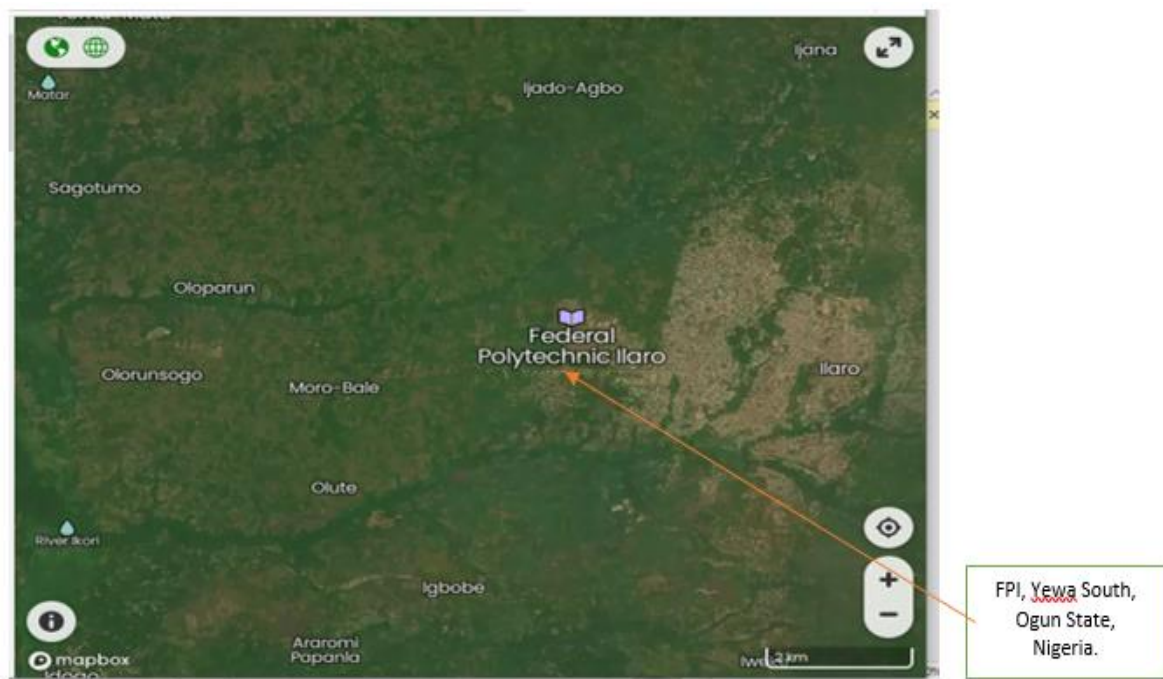

Figure 1. Geographical location of the experimental site.

Experimental Design Description

The set-up of the experiment consists of a water source from a bore hole located 45 m away from the study site connected to a pumping machine which pumps water to a water storage tank located on the field. Two valves were fitted after the pump to control the flow rate reaching the sprinkler device. A pressure gauge (up to 200 kPa) and flow meter were connected in series with the pressure regulator (Model 100 PRV) and sprinkler riser of height 1.2 meters. The pressure regulator was used to regulate the supply pressure to the test unit of sprinkler system. A set of PVC pipes of diameter 25 mm was used to convey water from the pumping site via the water storage tank to the sprinkler riser.

The design of the field trials was in line with sprinkler irrigation practices in terms of sprinkler spacing and range of operating pressure heads. The experiments were performed using 360° rotating sprinkler and a single nozzle of diameter 3 mm. The sprinkler was set up at a height 1.2 m and 27° as a trajectory angle. Three operating pressures, namely, 50 kPa, 100 kPa and 150 kPa (representing low pressure, medium pressure and high pressure, respectively) were used.

Measurement of the flow rate of sprinkler was done by connecting a flexible tube to the sprinkler nozzle and collecting known volume of water in a container over a specified period (5 min). The flow rate was calculated using the following formula ([Melvyn, 1983](#)).

$$Q = \frac{V}{t} \quad (1)$$

Where, Q is the flow rate of sprinkler in $\text{m}^3 \text{h}^{-1}$, V is the volume of water collected in m^3 and t is the time taken to collect the water in hours.

Water application rate of sprinkler was obtained with the aid of catch cans installed around the sprinkler under different treatments. This was calculated with the following formula ([James, 1988](#)).

$$A = k \frac{Q}{a} \quad (2)$$

Where, A is the application rate in mm h^{-1} , Q is the flow rate of sprinkler in L min^{-1} , a is the wetted area of sprinkler in m^2 and k is a dimensionless constant ($k = 60.0$ for A in mm h^{-1} , Q in L min^{-1} and a in m^2).

A mini automatic weather station consists of **multiple sensors** which provide data about air temperature, wind speed and direction (at 6 m), rainfall, snow depth, relative humidity, and solar radiation was installed very close to the experimental site during the study period to collect important climatic data (Table 1). Data were obtained from the station on hourly basis during the experiment. The effective winds direction during first three months of the study were from northwest, while it was southwest for the remaining months (June to July) of the study.

Table 1. Mean climatic variables during the experiment.

Month	Mean Wind Speed (m s^{-1})	Mean Max. Air Temp. ($^{\circ}\text{C}$)	Mean Min. Air Temp. ($^{\circ}\text{C}$)	Mean Relative Humidity (%)	Precipitation (mm)
March	1.52 (± 0.33)	33.70 (± 0.25)	23.80 (± 0.34)	52.6 (± 2.10)	0.00
April	1.63 (± 0.42)	34.10 (± 1.02)	24.50 (± 0.56)	50.5 (± 1.76)	0.00
May	1.45 (± 0.22)	32.80 (± 0.41)	22.70 (± 0.90)	53.3 (± 1.87)	24.80
June	1.37 (± 0.13)	31.60 (± 0.17)	24.30 (± 0.75)	56.7 (± 1.56)	43.50
July	1.39 (± 0.61)	29.45 (± 0.43)	21.74 (± 0.54)	68.2 (± 3.22)	75.86

Water was supplied at a constant flow rate of the pump under each operating pressure of 50 kPa, 100 kPa and 150 kPa, respectively. The sprinkler spacing area was (10 m by 10 m) and divided into squares of 1 m^2 . A total of 100 catch-cans, each of diameter 9.5 cm and height 14.0 cm, were used for the experimental area. The catch-cans were laid on the ground surface at equal elevation. A catch-can placed at the center of each square represented the precipitation falling on that particular area.

Evaporation losses were then conventionally determined as the difference between the quantity of water leaving the nozzle (measured by a flow meter) and the quantity of water precipitated into catch-cans over the duration of 60 minutes. Multiple tests were undertaken during mid-day when the sun was high in the sky with substantial evaporative flux. The arrangement and coverage area of the sprinkler is as shown in the Figures 2a to 2c. The results of evaporation losses obtained under various operating pressures and climatic conditions were measured, while the data collected were statically analyzed using multiple regression analysis as presented in the following section.

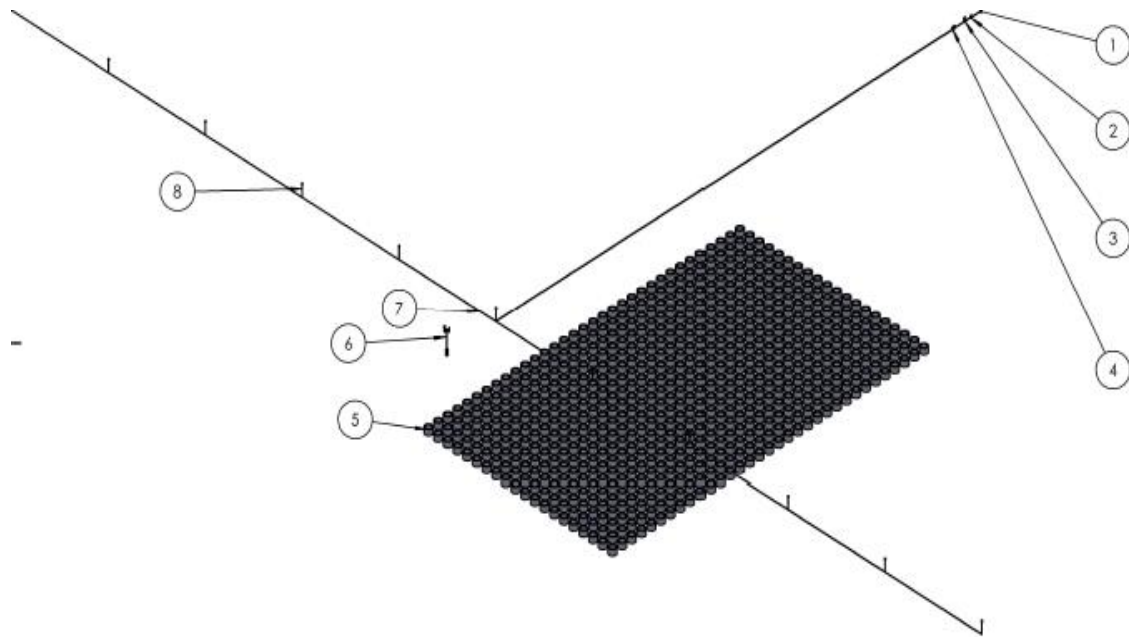
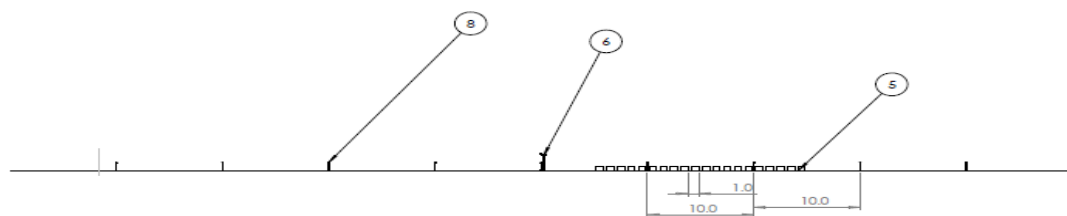

Figure 2a. Arrangement of the catch-cans around the sprinkler with the components.



S/No	Components
1	Water Source
2	Pressure Regulator
3	Pressure gauge
4	Flow meter
5	Catch can
6	Weather Station
7	Lateral Pipe
8	Sprinkler

Figure 2b. Arrangement of the catch-cans around the sprinkler with dimensions.

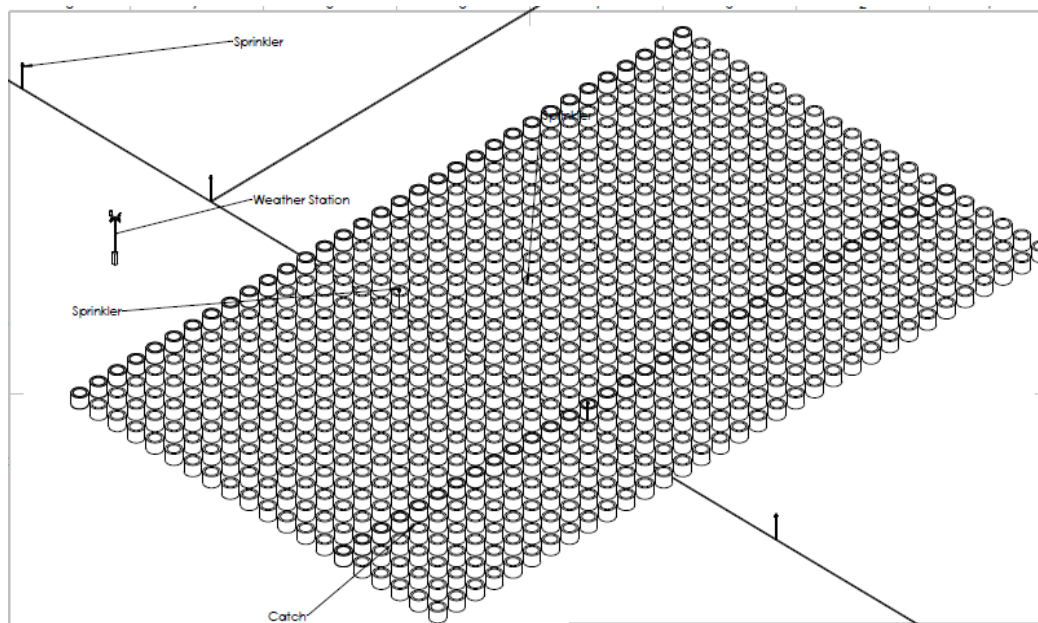

Figure 2c. Arrangement of the catch-cans around the sprinkler.

RESULTS AND DISCUSSION

The mean climatic variables during the five months of research were presented in Table 1. The maximum mean wind speed value of 1.63 m s^{-1} (± 0.43) was recorded in the second month of this study which is April while the least value of 1.37 m s^{-1} (± 0.13) was recorded in the month of June. For the mean maximum air temperature, the highest value of 33.70°C (± 0.25) was obtained in the month of March and the least value of 29.45°C (± 0.43) was recorded during the month of July. During the course of this study (March to July), relative humidity recorded the highest mean value of 68.2% (± 3.22) in the month of July while the least value of 50.5% (± 1.76) was obtained in the month of April. The analysis of precipitation data during the study indicated zero precipitation for the months of March and April. The two months were very hot and dry. Furthermore, the month of July witnessed the highest mean precipitation value of 75.86 mm during the study.

A total of 36 evaporation loss tests were carried out. Twelve experimental tests were conducted for each operating pressure of 50 kPa , 100 kPa and 150 kPa , respectively and the analysis of results obtained were shown in Table 2-4. The mean values of the tests carried out for each operating pressure were obtained and values are as presented below (Table 5). The results show that the mean percentage evaporation losses at 50 kPa operating pressure was 8.88% at a relative humidity of 62.08% , air temperature (T_a) of 30.76°C and wind speed (V_w) of 1.22 m s^{-1} . Also, the mean percentage evaporation losses at 100 kPa operating pressure was 13.21% at a relative humidity (RH) of 64.67% , air temperature of 31.61°C and wind speed of 1.72 m s^{-1} . At 150 kPa operating pressure, mean percentage evaporation losses recorded was 16.46% at a relative humidity (RH) of 65.17% and air temperature of 31.59°C and wind speed of 1.97 m s^{-1} . On the overall, the percentage evaporation losses at 50 kPa , 100 kPa and 150 kPa ranged from 6.94% to 9.93% , 12.43% to 14.23% and 16.02% to 17.32% , respectively. The mean values were further plotted to improve clarity and the understanding of the dependence of sprinkler

evaporation loss on the different variables (Figures 3 and 4). The results show that at higher relative humidity, percentage evaporation loss was higher. However, the multiple regression analysis results from the data pool of experimental I, II and III under operating pressure of 50 kPa, 100 kPa and 150 kPa in Table 6 showed that wind speed and air temperature play a significant role in predicting the percentage of water evaporated.

Table 2. Experimental results at low operating pressure, 50 kPa.

Trial No	Wind Speed (m s ⁻¹)	Air Temp. (°C)	Operating Pressure (kPa)	Relative Humidity (%)	Flow Rate (L s ⁻¹)	Droplet Height (m)	Volume Sprinkled (L)	Volume Precipitated (L)	Volume Evaporated (L)	Percentage Evaporated (%)
1	1.17	28.0	50	52.00	0.64	1.13	585.94	541.62	44.32	7.56
2	1.25	27.1	50	54.00	0.66	1.12	571.88	532.22	39.66	6.94
3	1.22	29.8	50	51.00	0.65	1.14	584.38	535.80	48.58	8.31
4	1.20	30.1	50	50.00	0.67	1.15	576.33	526.21	50.12	8.70
5	1.24	29.1	50	52.00	0.63	1.13	568.23	520.32	47.91	8.43
6	1.26	33.7	50	51.00	0.64	1.16	576.15	520.90	55.25	9.59
7	1.18	28.9	50	52.00	0.65	1.12	563.26	517.94	45.32	8.05
8	1.21	34.2	50	53.00	0.66	1.14	582.11	525.68	56.43	9.69
9	1.27	32.8	50	52.00	0.64	1.15	586.13	531.38	54.75	9.34
10	1.19	33.9	50	55.00	0.65	1.12	578.43	525.51	52.92	9.15
11	1.16	33.0	50	51.00	0.67	1.13	579.34	523.13	56.21	9.70
12	1.30	33.5	50	52.00	0.64	1.15	576.83	519.54	57.29	9.93
Average	1.22	30.76	50	52.08	0.65	1.14	577.42	526.60	50.81	8.88

Table 3. Experimental results at medium operating pressure, 100 kPa.

Trial No	Wind Speed (m s ⁻¹)	Air Temp. (°C)	Operating Pressure (kPa)	Relative Humidity (%)	Flow Rate (L s ⁻¹)	Droplet Height (m)	Volume Sprinkled (L)	Volume Precipitated (L)	Volume Evaporated (L)	Percentage Evaporated (%)
1	1.64	29.00	100.00	58.00	0.71	1.22	631.25	552.81	78.44	12.43
2	1.75	30.10	100.00	56.00	0.76	1.20	637.50	551.47	86.03	13.49
3	1.69	31.00	100.00	52.00	0.74	1.19	621.88	542.96	78.92	12.69
4	1.67	28.80	100.00	57.00	0.75	1.18	634.33	554.67	79.66	12.56
5	1.69	31.00	100.00	54.00	0.74	1.21	625.45	540.53	84.92	13.58
6	1.85	32.10	100.00	55.00	0.76	1.22	636.35	553.58	82.77	13.01
7	1.72	33.50	100.00	51.00	0.72	1.18	642.13	555.81	86.32	13.44
8	1.81	32.40	100.00	53.00	0.74	1.22	640.22	554.87	85.35	13.33
9	1.69	31.60	100.00	55.00	0.76	1.19	632.81	548.14	84.67	13.38
10	1.73	31.80	100.00	58.00	0.73	1.21	631.82	547.46	84.36	12.35
11	1.76	34.20	100.00	56.00	0.72	1.22	626.93	537.72	89.21	14.23
12	1.69	33.80	100.00	51.00	0.76	1.23	632.65	543.87	88.78	14.03
Average	1.72	31.61	100.00	54.67	0.74	1.21	632.78	548.66	84.12	13.21

Table 4. Experimental results at high operating pressure, 150 kPa.

Trial No	Wind Speed (m s ⁻¹)	Air Temp. (°C)	Operating Pressure (kPa)	Relative Humidity (%)	Flow Rate (L s ⁻¹)	Droplet Height (m)	Volume Sprinkled (L)	Volume Precipitated (L)	Volume Evaporated (L)	Percentage Evaporated (%)
1	2.64	30.10	150.00	55.00	0.89	1.24	685.94	572.80	113.14	16.49
2	2.11	31.00	150.00	51.00	0.97	1.27	675.00	564.96	110.04	16.30
3	1.92	31.20	150.00	58.00	0.91	1.26	676.56	567.88	108.68	16.06
4	1.87	32.10	150.00	58.00	0.91	1.25	681.22	570.00	111.22	16.33
5	1.93	29.80	150.00	55.00	0.89	1.26	678.45	569.78	108.67	16.02
6	1.79	30.60	150.00	56.00	0.85	1.24	669.23	561.41	107.82	16.10
7	1.82	32.40	150.00	51.00	0.90	1.26	691.34	578.43	112.91	16.33
8	1.91	31.60	150.00	58.00	0.87	1.27	689.65	577.29	112.36	16.29
9	1.88	32.70	150.00	53.00	0.89	1.28	673.23	561.41	111.82	16.61
10	1.85	33.20	150.00	55.00	0.91	1.26	667.12	551.56	115.56	17.32
11	1.94	31.90	150.00	56.00	0.86	1.24	688.78	514.25	114.53	16.63
12	1.92	32.50	150.00	56.00	0.88	1.28	672.66	557.78	114.88	17.08
Average	1.97	31.59	150.00	55.17	0.89	1.26	679.10	562.30	111.80	16.46

Table 5. Mean values of variables influencing evaporation losses obtained from the three experiments.

Trial No	Wind Speed (m s ⁻¹)	Air Temp (°C)	Operating Pressure (kPa)	Relative Humidity (%)	Flow Rate (L s ⁻¹)	Droplet height (m)	Volume Sprinkled (L)	Volume precipitated (L)	Volume Evaporated (L)	Percentage Evaporated (%)
1	1.22	30.76	50.00	62.08	0.65	1.14	577.42	526.60	50.81	8.88
2	1.72	31.61	100.00	64.67	0.74	1.21	632.78	548.66	84.12	13.21
3	1.97	31.59	150.00	65.17	0.89	1.26	679.10	562.30	111.80	16.46

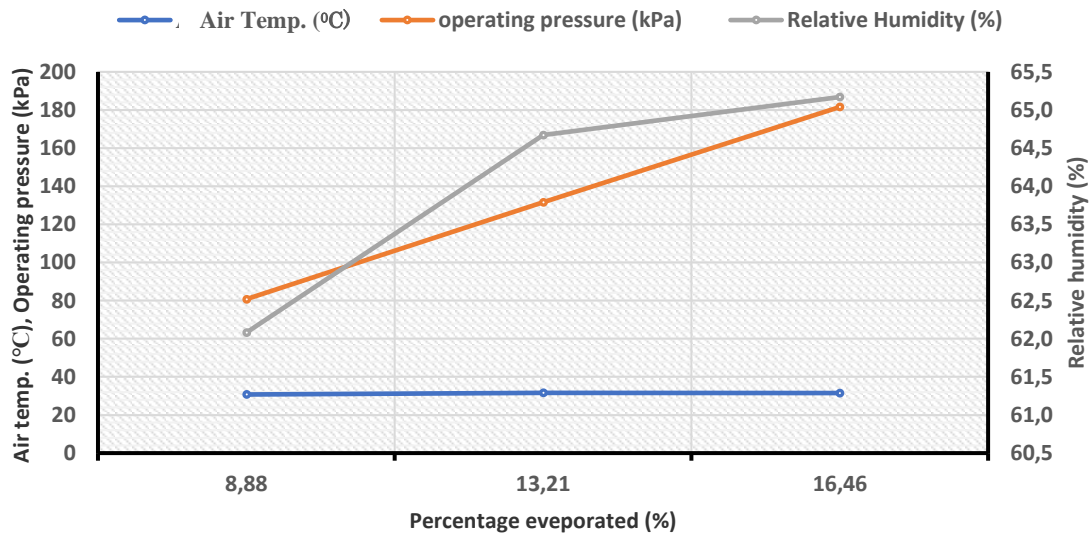

Figure 3. Variation of percentage evaporation losses with air temperature, operating pressure and relative humidity.

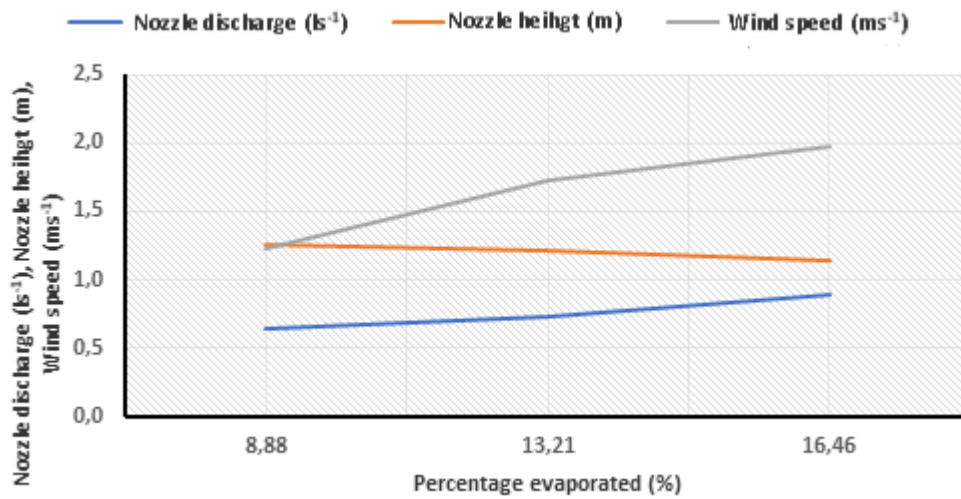

Figure 4. Variation of percentage evaporation losses with nozzle discharge, nozzle height and wind speed.

Table 6. Results of multiple regression analysis of the predictors and percentage evaporated water of the pooled data.

Predictors	Coefficients	Standard Error	t Stat	P-value
Intercept	-19.977	6.491	-3.078	0.004
Wind Speed (m s ⁻¹)	7.968	0.718	11.099	0.000
Air Temperature (°C)	0.393	0.117	3.350	0.002
Relative Humidity (%)	0.137	0.098	1.399	0.171

$$y = 7.968 X_1 + 0.393X_2 - 19.977 \tag{3}$$

Where y is the predicted evaporated water (%), X₁ is the wind speed (m s⁻¹) and X₂ is the air temperature (°C).

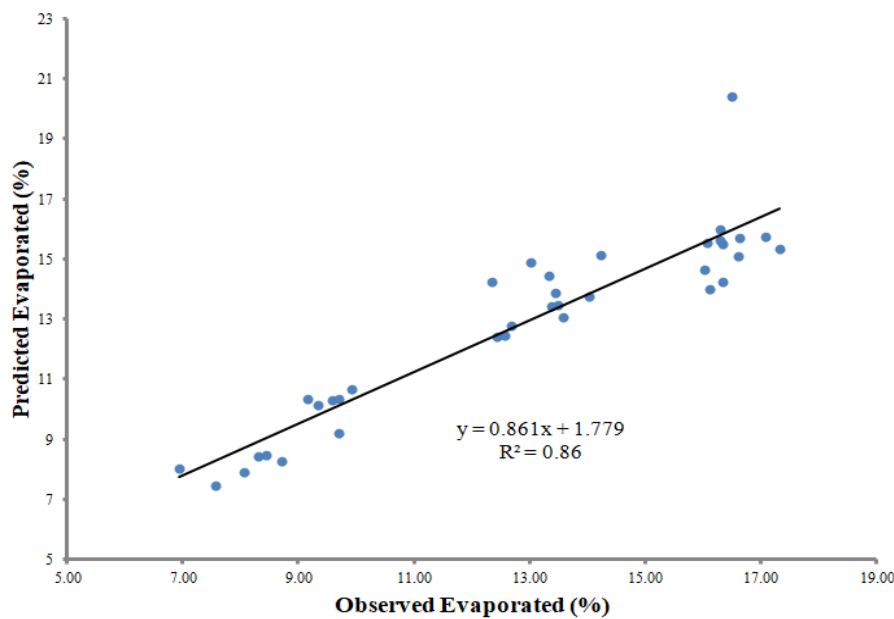

Figure 5. Relationship between the predicted and observed percentage evaporated water of the pooled data.

The occurrence of wind drift loss during irrigation is unavoidable ([Bavi *et al.*, 2017](#); [Kadam and Deshmukh, 2011](#)). During the study, drift losses/ evaporation losses increased with increasing operating pressure due to a reduction in droplet sizes. The sizes of droplets produced during sprinkler operations varied with the operating pressure. Large water droplets obtained in this study at low operating pressure became smaller as operating pressure increased. The large water droplets became smaller as the operating pressure was increased from 50 kPa to 150 kPa. In the same vein, similar increment in the operating pressure also resulted in high evaporation losses, especially under the conditions of low relative humidity, high wind speed and high air temperature. Generally, the size of water droplets increased with decreasing operating pressure, while evaporation losses increased with increasing operating pressure. This is because, larger droplets sizes are not easily blown away by wind drift and as a result, the reduction was observed in evaporation losses (wind drift loss).

However, the foregoing results are not surprising as similar observations have been recorded by previous studies ([Kohl *et al.*, 1987](#); [Uddin *et al.*, 2010](#)). While it may appear attractive to operate sprinklers at low pressure, given the result of the study, experts have recommended that sprinklers should be operated only under the operating pressure limit for which they are designed in order to avoid drift loss ([McLean, 2000](#); [Uddin *et al.*, 2010](#)). In addition, operating sprinkler at excessively low pressure, may increase friction losses, reduce coverage area and overall sprinkler efficiency. Meanwhile, the operation of sprinkler irrigation systems when wind speeds are high should be avoided to prevent excessive wind drift loss. This is because, wind drift loss increases as wind speeds increase and droplet size decreases ([Zazueta, 2011](#)), Fortunately, in recent time, most companies that are manufacturing sprinkler nozzles specifically designed it to minimize effects of droplet size and wind drift loss ([Uddin *et al.*, 2010](#)).

Moreover, in this study, at higher relative humidity, percentage evaporation loss was higher. This is contrary to the established principle of lower evaporation at higher relative humidity, as moist air absorbs less water and vice versa. However, the result may have been the consequence of the countering of the higher relative humidity by the combined effects of wind speed and higher air temperature. While [Zazueta \(2011\)](#) recently emphasized the prime importance of wind speed, air temperature and relative humidity in the estimation of sprinkler evaporation loss, [Lorenzini \(2002\)](#) had earlier argued that evaporation losses are greatly impacted by air temperature with an exponential relation.

In addition, plots of the results in Figures 3 and 4, further confirmed the predominance of the variables amongst the factors affecting sprinkler evaporation loss. Likewise, it is also obvious that nozzle operating heights had less influence compared to nozzle discharges, although both directly influenced the percentage evaporation losses due to wind drift losses when operating pressure was increased from 50 kPa to 150 kPa. The result of this study is comparable with the findings of [Uddin \(2010\)](#), [Frost and Schwalen \(1960\)](#) and [McLean \(2000\)](#).

Moreover, in Table 6, the regression analysis showed the predictors, their coefficients and significance levels at $p < 0.05$. It can be interpreted that air temperature and wind speed are the major parameters that were significant on the influence of the experiment to predict the percentage evaporated water under those operating pressures of 50 kPa, 100 kPa and 150 kPa respectively in this location. While the relative humidity was a

predictor too, but it influences on the model (Eqn.3) generated by regression analysis to predict the percentage evaporated water was not significant at $p < 0.05$. Hence, it was played down on (removed). The graph in Figure 5, shows the relationship between the predicted and observed evaporated water. The graph shows a perfect linear relationship with a model $y = 0.861x + 1.779$. The model was found to be significant at $p < 0.05$. The coefficient of determination was a strong value ($R^2 = 0.87$). This indicates that model ($y = 7.968X_1 + 0.393X_2 - 19.977$) as the predicted can be used to generate the observed percentage evaporated water in this location with 87% accuracy under the operating pressure of 50, 100 and 150 kPa respectively. This is comparable with the findings of [Uddin \(2010\)](#), [Frost and Schwalen \(1960\)](#) and [McLean \(2000\)](#).

CONCLUSION

In conclusion, the present study was conceived to evaluate the magnitude of sprinkler evaporation losses under varied operating pressures and climatic conditions in Ilaro, Ogun State, Nigeria. Twelve experiments were performed at three (3) different operating pressures 50 kPa, 100 kPa and 150 kPa, representing low pressure, medium pressure and high pressure, respectively. We observed large water droplets at low operating pressure which became smaller as operating pressure increased. However, drift losses/ evaporation losses also increased with increasing operating pressure due to reduced droplet size. Furthermore, under increasing relative humidity, increasing evaporation losses were also noted as consequences of the combined effects of wind speed and air temperature. Consequently, we conclude that even at the optimum sprinkler operating conditions, climate demand (temperature, wind speed, wind drift) becomes the predominant variable determining evaporation loss. Hence, it is recommended that sprinkler irrigation should be operated with due cognizance to the prevailing climatic condition in general and particularly in Ilaro. From the statistical analysis, $y = 7.968X_1 + 0.393X_2 - 19.977$ may be recommended for predicting percentage evaporation losses at this site during this season winter/autumn. Additionally, the present study was conducted during the spring/summer season when relative humidity is usually high. Therefore, a similar experiment during the winter/autumn season may be necessary to further confirm the present results, and this will be the focus of our next research.

DECLARATION OF COMPETING INTEREST

The authors declare that they have no conflict of interest.

CREDIT AUTHORSHIP CONTRIBUTION STATEMENT

Samuel Dare Oluwagbayide: Conceptualization, methodology, investigation and writing of the original draft.

Olugbenga Fasanu: Data analysis and editing of drafted copy.

Ajayi Johnson Oloruntade: Data collection, original drafting and editing of drafted copy.

REFERENCES

- Bavi A, Boroomand-Nasab S and Naseri A (2017). Spatial and temporal variability of infiltration parameters in furrow irrigation. *World Rural Observations*, 9(3): 65-72.
- Christiansen JE (1942). Irrigation by sprinkling. *California agricultural experiment station bulletin 670*. University of California, Berkeley, CA, 4275.
- Dasila B, Singh V, Kushwaha HS, Srivastava A and Ram S (2016). Water use efficiency and yield of cowpea and nutrient loss in lysimeter experiment under varying water table depth, irrigation schedules and irrigation method. *SAARC Journal of Agriculture*, 14(2): 46-55.
- FAO-Aquastat (2016). Food and Agriculture Organization. Aquastat Project. FAO. Rome. <http://www.fao.org/nr/water/aquastat/main/index.stm>.
- Frost KR, Schwalen HC (1955) Sprinkler evaporation losses. *Agricultural Engineering*, 36(8): 526-528.
- Irmak S, Odhiambo LO, Kranz WL and Eisenhauer DE (2011). Irrigation efficiency and uniformity, and crop water use efficiency. *Biological Systems Engineering: Papers and Publications 451*. <https://digitalcommons.unl.edu/biosysengfacpub/451>
- James LG (1988). Principles of Farm Irrigation System Design. *John Wiley & Sons*. 543 p.
- Jensen ME (1980). Design and operation of farm irrigation systems (No. 631.587/J51). *American Society of agricultural engineers*.
- Kadam SA and Deshmukh VV (2011). Effect of nozzle size on evaporation and drift losses from mini-sprinkler. *International Journal of Agricultural Engineering*, 4(2), 130-132. http://www.researchjournal.co.in/upload/assignments/4_130-132.pdf
- Kohl KD, Kohl RA and DeBoer DW (1987). Measurement of low-pressure sprinkler evaporation loss. *Transactions of the ASAE*, 30(4): 1071-1074.
- Kraus JH (1966). Application efficiency of sprinkler irrigation and its effects on microclimate. *Transactions of the ASAE*, 9(5): 642-645.
- Lorenzini G (2002). Air temperature effect on spray evaporation in sprinkler irrigation. *Irrigation and Drainage: The journal of the International Commission on Irrigation and Drainage*, 51(4): 301-309.
- McJannet DL, Cook FJ and Burn S (2013). Comparison of techniques for estimating evaporation from an irrigation water storage. *Water Resources Research*, 49(3): 1415-1428.
- McLean RK, Ranjan S and Klassen G (2000). Spray evaporation losses from sprinkler irrigation systems. *Canadian Agricultural Engineering*, 42(1): 1-8.
- Melvyn K (1983). Sprinkler irrigation, equipment and practice. *Batsford Academic and Educational, London*. 120p.
- National Population Commission (2006). National population census. Abuja, Nigeria: National Population Commission, 422.
- Phogat V, Šimůnek J, Skewes MA, Cox JW and McCarthy MG (2016). Improving the estimation of evaporation by the FAO-56 dual crop coefficient approach under subsurface drip irrigation. *Agricultural Water Management*, 178: 189-200.
- Stambouli T, Martínez-Cob A, Faci JM, Howell T and Zapata N, (2013). Sprinkler evaporation losses in alfalfa during solid-set sprinkler irrigation in semiarid areas. *Irrigation science*, 31(5): 1075-1089
- Sternberg YM (1967). Analysis of sprinkler irrigation losses. *Journal of the Irrigation and Drainage Division*, 93(4): 111-124.
- Strong WC (1961). Advanced irrigation. *Proceeding of an International Irrigation Symposium Southern Rhodesia*, pp.242-246.
- Uddin J, Hancock NH, Smith RJ and Foley JP (2013a). Measurement of evapotranspiration during sprinkler irrigation using a precision energy budget (Bowen ratio, eddy covariance) methodology. *Agricultural Water Management*, 116: 89-100.
- Uddin J, Smith R J, Hancock NH and Foley JP (2013b). Evaporation and sapflow dynamics during sprinkler irrigation of cotton. *Agricultural water management*, 125: 35-45.
- Uddin J, Smith R, Hancock N and Foley JP (2010). Droplet evaporation losses during sprinkler irrigation: an overview. *In Australian Irrigation Conference and Exhibition 2010: Proceedings (pp. 1-10)*. Irrigation Australia Ltd. <https://core.ac.uk/reader/11041126>
- Zazueta FS (2011). Evaporation loss during sprinkler irrigation. Gainesville, Florida: IFAS Extension. <https://edis.ifas.ufl.edu/ae048>